

REGENICIN, INC.

FORM POS AM

(Post-Effective Amendment to Registration Statement)

Filed 03/22/10

Address	10 HIGH COURT LITTLE FALLS, NJ 07424
Telephone	646-403-3581
CIK	0001412659
Symbol	RGIN
SIC Code	3564 - Industrial and Commercial Fans and Blowers and Air Purification Equipment
Industry	Biotechnology & Drugs
Sector	Healthcare
Fiscal Year	09/30

U.S. SECURITIES AND EXCHANGE COMMISSION
WASHINGTON, D.C. 20549

FORM S-1
(Post-Effective Amendment No. 3 to Form S-1)
REGISTRATION STATEMENT UNDER THE SECURITIES ACT OF 1933

Windstar, Inc.

(Exact name of Registrant as specified in its charter)

Nevada

(State or other jurisdiction of incorporation or organization)

**No 47 Hala Pegoh,
8 Taman Sri Pengkalan 31650
Ipoh, Perak, Malaysia
(014) 327-4470**

(Address, including zip code, and telephone number, including area code,
of Registrant's principal executive offices)

TBA

(I.R.S. Employer Identification Number)

**Nevada Agency and Trust Company
50 West Liberty St, Suite 880
Reno, NV 89501
(775) 322-0626**

(Address, including zip code, and telephone number, including
area code, of agent for service of process)

Primary Standard Industrial Classification Code Number: **3564**

Approximate date of commencement of proposed sale to the public:

**As soon as practicable after the effective
date of this Registration Statement .**

If any of the securities being registered on the Form are to be offered on a delayed or continuous basis pursuant to Rule 415 under the Securities Act of 1933, other than securities offered only in connection with dividend or interest reinvestment plans, check the following box | |

If this Form is filed to register additional securities for an offering pursuant to Rule 462(b) under the Securities Act, check the following box and list the Securities Act registration statement number of the earlier effective registration statement for the same offering.

If this Form is a post-effective amendment filed pursuant to Rule 462(c) under the Securities Act, check the following box and list the Securities Act registration statement number of the earlier effective registration statement for the same offering.

If this Form is a post-effective amendment filed pursuant to Rule 462(d) under the Securities Act, check the following box and list the Securities Act registration statement number of the earlier effective registration statement for the same offering.

Indicate by check mark whether the registrant is a large accelerated filer, an accelerated filer, a non-accelerated filer, or a smaller reporting company.

Large accelerated filer Accelerated filer Non-accelerated filer Smaller reporting company | |

THE REGISTRANT HEREBY AMENDS THIS REGISTRATION STATEMENT ON SUCH DATE OR DATES AS MAY BE NECESSARY TO DELAY ITS EFFECTIVE DATE UNTIL THE REGISTRANT SHALL FILE A FURTHER AMENDMENT WHICH SPECIFICALLY STATES THAT THIS REGISTRATION STATEMENT SHALL THEREAFTER BECOME EFFECTIVE IN ACCORDANCE WITH SECTION 8(a) OF THE SECURITIES ACT OF 1933 OR UNTIL THE REGISTRATION STATEMENT SHALL BECOME EFFECTIVE ON SUCH DATE AS THE COMMISSION, ACTING PURSUANT TO SECTION 8(a), MAY DETERMINE.

COPIES OF COMMUNICATIONS TO:

**David S. Jennings, Esq.
330 Carousel Parkway, Henderson, Nevada 89014
Phone: (702) 595-5150 / Fax: (800) 731-6120**

Explanatory Note

The Registrant files this post-effective amendment number three to its Registration Statement on Form SB-2 (No. 333-146834) as initially filed with the Securities and Exchange Commission on October 22, 2007.

The Registrant previously paid a registration fee of \$0.58 in connection with the filing of the initial registration statement on Form SB-2 (No. 333-146834) filed with the Securities and Exchange Commission on October 22, 2007.

This post-effective amendment number three is being filed: (1) to delete a selling shareholder from the list of selling shareholders, and to reestablish the correct number of shares offered, and (2) **to include the audited financials for the years ended September 30, 2009 and 2008, and the unaudited financials for the three months ended December 31, 2009.**

The information in this prospectus is not complete and may be changed. We may not sell these securities until the registration statement filed with the Securities and Exchange Commission is effective. The prospectus is not an offer to sell these securities and it is not soliciting an offer to buy these securities in any state where the offer or sale is not permitted.

SUBJECT TO COMPLETION, Dated March 17, 2010

**PROSPECTUS
WINDSTAR, INC.**

925,000

SHARES OF

COMMON STOCK

The selling shareholders named in this prospectus are offering up to 925,000 shares of common stock offered through this prospectus. We will not receive any proceeds from this offering and have not made any arrangements for the sale of these securities.

		Underwriting	-
		Discounts and	-
		Commissions	<u>Proceeds to Selling</u>
Per Share	<u>Offering Price</u>	None	<u>Shareholders</u>
Total	\$0.02	None	\$0.02
	\$18,500	None	\$18,500

Our common stock is quoted on the Financial Industry Regulatory Authority's Over the Counter Bulletin Board ("OTCBB") under the symbol "WDST." Because we have not had an active trading market for our common stock, however, we have set an offering price for these securities of \$0.02 per share. If our common stock becomes actively traded on the OCTBB, then the sale price to the public will vary according to prevailing market prices or privately negotiated prices by the selling shareholders.

The purchase of the securities offered through this prospectus involves a high degree of risk. See section entitled "Risk Factors" starting on page 6.

Neither the Securities and Exchange Commission nor any state securities commission has approved or disapproved of these securities or passed upon the adequacy or accuracy of this prospectus. Any representation to the contrary is a criminal offense.

The Date of This Prospectus is: March 17, 2010

Table of Contents

	Page
SUMMARY	5
RISK FACTORS	7
RISKS ASSOCIATED WITH OUR FINANCIAL CONDITION	7
<i>Because our auditor has issued a going concern opinion regarding our company, there is an increased risk associated with an investment in our company.</i>	7
<i>Because we have a limited operating history, it is difficult to evaluate your investment in our stock.</i>	7
RISKS ASSOCIATED WITH OUR BUSINESS MODEL	8
<i>Because we have not established the Windstar brand name, and our products and name have little, if any, name recognition, we may be prevented from generating revenues which will reduce the value of your investment.</i>	8
<i>If the air purifier market does not experience significant growth or if our products do not achieve broad acceptance, we will not be able to achieve revenues.</i>	8
<i>Because we conduct our business through verbal agreements with consultants and arms-length third parties, there is a substantial risk that such persons may not be readily available to us and the implementation of our business plan could be impaired.</i>	8
<i>Because we do not have exclusive agreements with the third party manufacturers that will manufacture our products, we may be unable to effectively manufacture and distribute our products or distribute them at all, which would adversely affect our reputation and materially reduce our revenues.</i>	9
<i>If we are unable to gauge trends and react to changing consumer preferences in a timely manner, our sales will decrease, and our business may fail.</i>	9
<i>In the event that we are unable to successfully compete within the air purification business, we may not be able to achieve profitable operations.</i>	9
<i>Because we will be forced to rely on third party manufacturers and raw material suppliers, the occurrence of difficulties outside of our control could negatively impact our business.</i>	10
<i>The complexity of our Product may lead to errors, defects, and bugs, which could subject us to significant costs or damages and adversely affect market acceptance of our Product.</i>	11
<i>If we do not effectively implement measures to sell our product, we may never achieve revenues and you will lose your entire investment.</i>	11
<i>If we are unable to successfully manage growth, our operations could be adversely affected.</i>	11
<i>Because we intend to offer our Product in the Philippines, China, and other countries throughout Asia, we are subject to risks associated with international operations.</i>	12
RISKS ASSOCIATED WITH MANAGEMENT AND CONTROL PERSONS	12
<i>Because our management is inexperienced in operating an air purifier business, our business plan may fail.</i>	12
<i>Because our management has only agreed to provide their services on a part-time basis, they may not be able or willing to devote a sufficient amount of time to our business operations, causing our business to fail.</i>	13
<i>If we are unable to hire and retain key personnel, we may not be able to implement our business plan.</i>	13
<i>Because our officer and director, Siew Mee Fam, and our director, Sze Yein Wong, own an aggregate of 55.8% of our outstanding common stock, investors may find that corporate decisions influenced by Siew Mee Fam and Sze Yein Wong are inconsistent with the best interests of other stockholders.</i>	13
<i>Because our officer and director, Siew Mee Fam, and our director, Sze Yein Wong, own an aggregate of 55.8% of our outstanding common stock, the market price of our shares would most likely decline if they were to sell a substantial number of shares all at once or in large blocks.</i>	13
RISKS RELATED TO LEGAL UNCERTAINTY	14
<i>If our products are found to cause injury, have defects, or fail to meet industry standards, we will incur substantial litigation, judgment, product liability, and product recall costs, which will increase our losses and negatively affect our brand name reputation and product sales.</i>	14
<i>Even though we are not manufacturing the products ourselves, if any of the products we sell infringe on the intellectual property rights of others, we may find ourselves involved in costly litigation, which will negatively affect the financial results of our business operations.</i>	14
<i>New legislation, including the Sarbanes-Oxley Act of 2002, may make it more difficult for us to retain or attract officers and directors.</i>	14
RISKS RELATED TO OUR SECURITIES	15
<i>If a market for our common stock does not develop, shareholders may be unable to sell their shares.</i>	15
<i>If the selling shareholders sell a large number of shares all at once or in blocks, the market price of our shares would most likely decline.</i>	15
<i>If we issue shares of preferred stock with superior rights than the common stock registered in this prospectus, it could result in a decrease in the value of our common stock and delay or prevent a change in control of us.</i>	15
<i>If a public market for our common stock develops, short selling could increase the volatility of our stock price.</i>	16
<i>Because we do not expect to pay dividends for the foreseeable future, investors seeking cash dividends should not purchase our common stock.</i>	16
<i>Because we will be subject to the “Penny Stock” rules once our shares are quoted on the over-the-counter bulletin board, the level of trading activity in our stock may be reduced.</i>	16

FORWARD-LOOKING STATEMENTS	17
USE OF PROCEEDS	17
DETERMINATION OF OFFERING PRICE	17
DILUTION	17
SELLING SHAREHOLDERS	17
PLAN OF DISTRIBUTION	22
LEGAL PROCEEDINGS	24
DIRECTORS, EXECUTIVE OFFICERS, PROMOTERS AND CONTROL PERSONS	24
SECURITY OWNERSHIP OF CERTAIN BENEFICIAL OWNERS AND MANAGEMENT	25
DESCRIPTION OF SECURITIES	26
INTERESTS OF NAMED EXPERTS AND COUNSEL	30
DISCLOSURE OF COMMISSION POSITION OF INDEMNIFICATION FOR SECURITIES ACT LIABILITIES	30
ORGANIZATION WITHIN THE LAST FIVE YEARS	31
DESCRIPTION OF BUSINESS	31
DESCRIPTION OF PROPERTY	37
MANAGEMENT'S DISCUSSION AND ANALYSIS OF FINANCIAL CONDITION AND RESULTS OF OPERATIONS	37
CERTAIN RELATIONSHIPS AND RELATED TRANSACTIONS	41
MARKET FOR COMMON EQUITY AND RELATED STOCKHOLDER MATTERS	41
EXECUTIVE COMPENSATION	45
FINANCIAL STATEMENTS	47
CHANGES IN AND DISAGREEMENTS WITH ACCOUNTANTS	48
AVAILABLE INFORMATION	48

Summary

We were incorporated as Windstar, Inc. (“Windstar”) in the State of Nevada on September 6, 2007. We are engaged in the business of developing, producing, and marketing an effective and inexpensive air purification device (the “Product”) for distribution in the Philippines and other Asian countries.

We are a development stage company and have not generated sales to date. As of December 31, 2009, we had \$0 in current assets and current liabilities in the amount of \$18,500. Accordingly, we had a negative working capital position as of December 31, 2009 of \$18,500. Since our inception through December 31, 2009, we have incurred a net loss of \$61,500. We do not have sufficient capital to enable us to implement our business plan as set forth in this prospectus. For these and other reasons, our independent auditors have raised substantial doubt about our ability to continue as a going concern. Accordingly, we will require additional financing.

Our principal offices are located at No 47 Hala Pegoh, 8 Taman Sri Pengkalan 31650 Ipoh, Perak, Malaysia. Our phone number is (014) 327-4470. Our fiscal year end is September 30.

The Offering

Securities Being Offered	Up to 925,000 shares of our common stock, which includes all issued and outstanding shares with the exception of those held by our officer and director, Siew Mee Fam, and our director, Sze Yein Wong.
Offering Price	The offering price of the common stock is \$0.02 per share. We are quoted on the OTCBB under the symbol “WDST” but do not currently have an active trading market. If our common stock becomes so traded and a market for the stock develops, the actual price of stock will be determined by prevailing market prices at the time of sale or by private transactions negotiated by the selling shareholders. The offering price would thus be determined by market factors and the independent decisions of the selling shareholders.
Minimum Number of Shares To Be Sold in This Offering	None
Securities Issued and to be Issued	2,150,000 shares of our common stock are issued and outstanding as of the date of this prospectus. Our officer and director, Siew Mee Fam, and our director, Sze Yein Wong, own an aggregate of 55.8% of the common shares of our company and therefore have substantial control. All of the common stock to be sold under this prospectus will be sold by existing shareholders. There will be no increase in our issued and outstanding shares as a result of this offering.
Use of Proceeds	We will not receive any proceeds from the sale of the common stock by the selling shareholders.

Summary Financial Information

<u>Balance Sheet Data</u>	<u>As of December 31, 2009</u> <u>(Unaudited)</u>	<u>As of September 30, 2009</u> <u>(Audited)</u>	<u>As of September 30, 2008</u> <u>(Audited)</u>
Cash	\$0	\$0	\$0
Total Assets	\$0	\$0	\$0
Liabilities	\$18,500	\$16,500	\$5,500
Total Stockholders' Equity	\$18,500	\$16,500	\$5,500

<u>Statement of Operations</u>	<u>For the Quarter Ended</u> <u>December 31,</u> <u>2009 (Unaudited)</u>	<u>For the Year Ended</u> <u>September 30,</u> <u>2009 (Audited)</u>	<u>For the Year Ended</u> <u>September 30, 2009</u> <u>(Audited)</u>
Revenue	\$0	\$0	\$0
Loss for the Period	\$2,000	\$11,000	\$44,500

Risk Factors

Readers should carefully consider the risks and uncertainties described below before deciding whether to invest in shares of our common stock.

Our failure to successfully address the risks and uncertainties described below would have a material adverse effect on our business, financial condition and/or results of operations, and the trading price of our common stock may decline and investors may lose all or part of their investment. We cannot assure you that we will successfully address these risks or other unknown risks that may affect our business.

Risks Associated with Our Financial Condition

Because our auditor has issued a going concern opinion regarding our company, there is an increased risk associated with an investment in our company.

We have earned no revenue since our inception, which makes it difficult to evaluate whether we will operate profitably. Operating expenses for the period from September 6, 2007 (date of inception) to December 31, 2009, totaled \$61,500. We have incurred cumulative net losses of \$61,500 since September 6, 2007. We have not attained profitable operations and are dependent upon obtaining financing or generating revenue from operations to continue operations for the next twelve months. As of December 31, 2009, we had no cash. Our future is dependent upon our ability to obtain financing or upon future profitable operations. We reserve the right to seek additional funds through private placements of our common stock and/or through debt financing. Our ability to raise additional financing is unknown. We do not have any formal commitments or arrangements for the advancement or loan of funds. For these reasons, our auditors stated in their report that they have substantial doubt we will be able to continue as a going concern. As a result, there is an increased risk that you could lose the entire amount of your investment in our company.

Because we have a limited operating history, it is difficult to evaluate your investment in our stock.

Evaluation of our business will be difficult because we have a limited operating history. We are in the development stage of our business and have not yet begun to offer our products. To date, revenues are not substantial enough to maintain us without additional capital injection if we determine to pursue a growth strategy before significant revenues are generated. We face a number of risks encountered by early-stage companies, including our need to develop infrastructure to support growth and expansion; our need to obtain long-term sources of financing; our need to establish our marketing, sales and support organizations; and our need to manage expanding operations. Our business strategy may not be successful, and we may not successfully address these risks. If we are unable to sustain profitable operations, investors may lose their entire investment in us.

Risks Associated with Our Business Model

Because we have not established the Windstar brand name, and our products and name have little, if any, name recognition, we may be prevented from generating revenues which will reduce the value of your investment.

Because we are a new company with new products and we have not conducted advertising, there is little or no recognition of our Windstar brand name. As a result, consumers may purchase products other than ours that have brand recognition in the market and we may be unable to generate sufficient revenues to meet our expenses or meet our business plan objectives, which will reduce the value of your investment.

If the air purifier market does not experience significant growth or if our products do not achieve broad acceptance, we will not be able to achieve revenues.

We hope to achieve revenues from sales of our Product. We cannot accurately predict future growth rates or the size of the air purifier market. Demand for our Product may not occur as anticipated, or may decrease, either generally or in specific geographic markets, during particular time periods. The expansion of air purifier market and the market for our Product depends on a number of factors, such as:

- the cost, performance and reliability of our products and products offered by our competitors;
- public perceptions regarding the effectiveness and value of air purifiers;
- customer satisfaction with air purifiers; and
- marketing efforts and publicity regarding the needs for air purifiers.

Even if air purifiers gain wide market acceptance, our Product may not adequately address market requirements and may not continue to gain market acceptance. If air purifiers generally, or our Product specifically, does not gain wide market acceptance, we may not be able to achieve our anticipated level of growth, we may not achieve revenues and results of operations would suffer.

Because we conduct our business through verbal agreements with consultants and arms-length third parties, there is a substantial risk that such persons may not be readily available to us and the implementation of our business plan could be impaired.

Although we plan to pursue written agreements with our manufacturers to provide goods to us at their respective and customary rates upon request, we currently have no such written agreements in place. In addition, we have a verbal agreement with our accountants to perform requested financial accounting services and our outside auditors to perform auditing functions. Each of these functions requires the services of persons in high demand and these persons may not always be available. The implementation of our business plan and ability to services our customers may be impaired if we are not able to secure written agreements with additional manufacturers, or the parties with whom we have verbal agreements do not perform in accordance with our verbal agreements. In addition, it may be difficult to enforce a verbal agreement in the event that any of these parties fail to perform.

Because we do not have exclusive agreements with the third party manufacturers that will manufacture our products, we may be unable to effectively manufacture and distribute our products or distribute them at all, which would adversely affect our reputation and materially reduce our revenues.

We do not own or operate any manufacturing facilities. We plan to pursue and enter into written agreements with the third party manufacturers to manufacture our products and ship them directly to our customers. If we lose the services of our third party manufacturers, we may be unable to secure the services of replacement manufacturers. In addition, because we do not have written agreements with all of these manufacturers, they could refuse to supply some or all of our products, reduce the number of products that they supply or change the terms and prices under which they normally supply our products. The occurrence of any such conditions will have a materially negative effect upon our reputation and our ability to distribute our products, which will cause a material reduction in our revenues.

If we are unable to gauge trends and react to changing consumer preferences in a timely manner, our sales will decrease, and our business may fail.

We believe our success depends in substantial part on our ability to offer products and designs that reflect current needs and anticipate, gauge and react to changing consumer demands in a timely manner. Our business is vulnerable to changes in consumer preferences. We will attempt to reduce the risks of changing demands and product acceptance in part by devoting a portion of our available products and designs to standard products that are not significantly modified from year to year. Nevertheless, if we misjudge consumer needs for our products, our ability to generate sales could be impaired resulting in the failure of our business. There are no assurances that our future products will be successful, and in that regard, any unsuccessful products could also adversely affect our business.

In the event that we are unable to successfully compete within the air purification business, we may not be able to achieve profitable operations.

We face substantial competition in the industry. Due to our small size, it can be assumed that many of our competitors have significantly greater financial, technical, marketing and other competitive resources. These competitors may have completed development of their products and are presently marketing these to potential customers. Accordingly, these competitors may have already begun to establish brand-recognition with consumers. We will attempt to compete against these competitors by developing features that exceed the features offered by competing products. However, we cannot assure you that our products will outperform competing products or those competitors will not develop new products that exceed what we provide. In addition, we may face competition based on price. If our competitors lower the prices on their products, then it may not be possible for us to market our products at prices that are economically viable. Increased competition could result in:

- Lower than projected revenues;
- Price reductions and lower profit margins;

- The inability to develop and maintain our products with features and usability sought by potential customers.

Any one of these results could adversely affect our business, financial condition and results of operations. In addition, our competitors may develop competing products that achieve greater market acceptance. It is also possible that new competitors may emerge and acquire significant market share. Our inability to achieve sales and revenue due to competition will have an adverse effect on our business, financial condition and results of operations.

Because we will be forced to rely on third party manufacturers and raw material suppliers, the occurrence of difficulties outside of our control could negatively impact our business.

We do not have our own fabrication facilities, or assembly or manufacturing operations. Instead, we intend to rely on others to fabricate, assemble and manufacture all of our products. We do not have any long-term supply contracts with any of these suppliers. Because we intend to outsource the manufacture of all of our products, the cost, quality and availability of third-party manufacturing operations are essential to the successful production and sale of our products. Our reliance on third-party manufacturers exposes us to a number of risks which are outside our control, including:

- unexpected increases in manufacturing costs;
- interruptions in shipments if a third-party manufacturer is unable to complete production in a timely manner;
- inability to control quality of finished products;
- inability to control delivery schedules;
- inability to control production levels and to meet minimum volume commitments to our customers;
- inability to control manufacturing yield;
- inability to maintain adequate manufacturing capacity; and
- inability to secure adequate volumes of acceptable components, at suitable prices or in a timely manner.

We have not yet located a manufacturer for our products. We may be unable to locate a suitable manufacturer for our products on terms acceptable to us, or at all. The occurrence of any such conditions discussed herein will have a materially negative effect upon our reputation and our ability to distribute our products, which will cause a material reduction in any revenues that we hope to achieve.

The complexity of our Product may lead to errors, defects, and bugs, which could subject us to significant costs or damages and adversely affect market acceptance of our Product.

We have not undertaken significant testing of our Product and it may contain undetected errors, weaknesses, defects or bugs when first introduced or as new versions are released. If our Product or future products contain production defects, reliability, quality or compatibility problems that are significant to our customers, our reputation may be damaged and customers may be reluctant to continue to buy our products, which could adversely affect our ability to retain and attract new customers. In addition, these defects or bugs could interrupt or delay sales of affected products, which could adversely affect our results of operations.

If defects or bugs are discovered after commencement of commercial production of our Product or future products, we may be required to make significant expenditures of capital and other resources to resolve the problems. This could result in significant additional development costs and the diversion of technical and other resources from our other development efforts. We could also incur significant costs to repair or replace defective products. These costs or damages could have a material adverse effect on our financial condition and results of operations.

If we do not effectively implement measures to sell our product, we may never achieve revenues and you will lose your entire investment.

We are currently testing and refining our prototype Product, which we have built in our facility in the Philippines. When we are satisfied that our Product provides the most effective air purification possible for the consumer, we will begin the manufacture and distribution of the Product to retailers throughout the Philippines before expanding to mainland China and other Asian countries. We have not achieved revenues, or taken active steps to develop a sales force to attain revenues. We have no experience in providing direct sales and service, nor do we have distributors of our Product. Moreover, our sales and marketing efforts may not achieve intended results and therefore may not generate the revenue we hope to achieve. As a result of our corporate strategies, we have decided to initially focus our resources in select areas in the Philippines. We may change our focus to other markets or applications in the future. There can be no assurance that our focus or our near term plans will be successful. If we are not able to successfully address markets for our products, we may not be able to grow our business, compete effectively or achieve profitability.

If we are unable to successfully manage growth, our operations could be adversely affected.

Our progress is expected to require the full utilization of our management, financial and other resources, which to date has occurred with limited working capital. Our ability to manage growth effectively will depend on our ability to improve and expand operations, including our financial and management information systems, and to recruit, train and manage sales personnel. There can be no absolute assurance that management will be able to manage growth effectively.

If we do not properly manage the growth of our business, we may experience significant strains on our management and operations and disruptions in our business. Various risks arise when companies and industries grow quickly. If our business or industry grows too quickly, our ability to

meet customer demand in a timely and efficient manner could be challenged. We may also experience development or production delays as we seek to meet increased demand for our products. Our failure to properly manage the growth that we or our industry might experience could negatively impact our ability to execute on our operating plan and, accordingly, could have an adverse impact on our business, our cash flow and results of operations, and our reputation with our current or potential customers.

Because we intend to offer our Product in the Philippines, China, and other countries throughout Asia, we are subject to risks associated with international operations.

Although we have not commenced manufacturing our Product to consumers, we may rely on foreign third-party manufacturing, assembly and testing operations. Foreign operations subject us to a number of risks associated with conducting business outside of the United States, including the following:

- Unexpected changes in, or impositions of, legislative or regulatory requirements;
- Delays resulting from difficulty in obtaining export licenses for certain technology, tariffs, quotas and other trade barriers and restrictions;
- Imposition of additional taxes and penalties;
- The burdens of complying with a variety of foreign laws; and
- Other factors beyond our control, including acts of terrorism, which may delay the shipment of our products, impair our ability to travel or our ability to communicate with foreign locations.

In addition, the laws of certain foreign countries in which our products are or may be designed, manufactured or sold may not protect our products or intellectual property rights to the same extent as the laws of the United States. This increases the possibility of piracy of our technology and products.

Risks Associated with Management and Control Persons

Because our management is inexperienced in operating an air purifier business, our business plan may fail.

Our management does not have any specific training in running an air purifier business. With no direct training or experience in this area, our management may not be fully aware of many of the specific requirements related to working within this industry. As a result, our management may lack certain skills that are advantageous in managing our company. Consequently, our operations, earnings, and ultimate financial success could suffer irreparable harm due to management's lack of experience in this industry.

Because our management has only agreed to provide their services on a part-time basis, they may not be able or willing to devote a sufficient amount of time to our business operations, causing our business to fail.

Siew Mee Fam, our officer and director, devotes 10 to 15 hours per week to our business affairs. We do not have an employment agreement with Siew Mee Fam, nor do we maintain key life insurance for him. Currently, we do not have any full or part-time employees. If the demands of our business require the full business time of our management, it is possible that they may not be able to devote sufficient time to the management of our business, as and when needed. If our management is unable to devote a sufficient amount of time to manage our operations, our business will fail.

If we are unable to hire and retain key personnel, we may not be able to implement our business plan.

Due to the specified nature of our business, having certain key personnel is essential to the development and marketing of the products we plan to sell and thus to the entire business itself. Consequently, the loss of any of those individuals may have a substantial effect on our future success or failure. We may have to recruit qualified personnel with competitive compensation packages, equity participation, and other benefits that may affect the working capital available for our operations. Management may have to seek to obtain outside independent professionals to assist them in assessing the merits and risks of any business proposals as well as assisting in the development and operation of many company projects. No assurance can be given that we will be able to obtain such needed assistance on terms acceptable to us. Our failure to attract additional qualified employees or to retain the services of key personnel could have a material adverse effect on our operating results and financial condition.

Because our officer and director, Siew Mee Fam, and our director, Sze Yein Wong, own an aggregate of 55.8% of our outstanding common stock, investors may find that corporate decisions influenced by Siew Mee Fam and Sze Yein Wong are inconsistent with the best interests of other stockholders.

Siew Mee Fam is our officer and a member of our board of directors. Sze Yein Wong is our director. Together, they own approximately 55.8% of the outstanding shares of our common stock. Accordingly, they will have an overwhelming influence in determining the outcome of all corporate transactions or other matters, including mergers, consolidations and the sale of all or substantially all of our assets, and also the power to prevent or cause a change in control. While we have no current plans with regard to any merger, consolidation or sale of substantially all of our assets, the interests of Siew Mee Fam and Sze Yein Wong may still differ from the interests of the other stockholders.

Because our officer and director, Siew Mee Fam, and our director, Sze Yein Wong, own an aggregate of 55.8% of our outstanding common stock, the market price of our shares would most likely decline if they were to sell a substantial number of shares all at once or in large blocks.

Our officer and director, Siew Mee Fam owns 600,000 shares of our common stock, which equates to 27.9% of our outstanding common stock. Our director, Sze Yein Wong owns 600,000 shares of our common stock, which equates to 27.9% of our outstanding common stock. There is presently no public market for our common stock although we plan to apply for quotation of our common stock on the NASD over-the-counter bulletin board upon the effectiveness of the registration statement of which this prospectus forms a part. If our shares are publicly traded on the over-the-counter bulletin board, Siew Mee Fam and Sze Yein Wong will be eligible to sell their shares publicly subject to the volume limitations in Rule 144. The offer or sale of a large number of shares at any price may cause the market price to fall. Sales of substantial amounts of common stock or the perception that such transactions could occur may materially and adversely affect prevailing markets prices for our common stock.

Risks Related to Legal Uncertainty

If our products are found to cause injury, have defects, or fail to meet industry standards, we will incur substantial litigation, judgment, product liability, and product recall costs, which will increase our losses and negatively affect our brand name reputation and product sales.

Because our products are intended for use in a home environment, we may be subject to liability for any accidents or injury that may occur in connection with the use of these products or due to claims of defective design, integrity or durability of the products. We do not currently maintain liability insurance coverage for such claims. If we are unable to obtain such insurance, product liability claims could adversely affect our brand name reputation, revenues and ultimately lead to losses. In addition, product defects could result in product recalls and warranty claims. A product recall could delay or halt the sale of our products until we are able to remedy the product defects. The occurrence of any claims, judgments, or product recalls will negatively affect our brand name image and product sales, as well as lead to additional costs.

Even though we are not manufacturing the products ourselves, if any of the products we sell infringe on the intellectual property rights of others, we may find ourselves involved in costly litigation, which will negatively affect the financial results of our business operations.

Although we have not received notices of any alleged infringement, we cannot be certain that our Products do not infringe on issued trademarks and/or copyright rights of others. We may be subject to legal proceedings and claims from time to time in our ordinary course of business arising out of intellectual property rights of others. These legal proceedings can be very costly, and thus can negatively affect the results of our operations.

New legislation, including the Sarbanes-Oxley Act of 2002, may make it more difficult for us to retain or attract officers and directors.

The Sarbanes-Oxley Act of 2002 was enacted in response to public concerns regarding corporate accountability in connection with recent accounting scandals. The stated goals of the Sarbanes-Oxley Act are to increase corporate responsibility, to provide for enhanced penalties for accounting and auditing improprieties at publicly traded companies, and to protect investors by improving the

accuracy and reliability of corporate disclosures pursuant to the securities laws. The Sarbanes-Oxley Act generally applies to all companies that file or are required to file periodic reports with the SEC, under the Securities Exchange Act of 1934. Upon becoming a public company, we will be required to comply with the Sarbanes-Oxley Act. The enactment of the Sarbanes-Oxley Act of 2002 has resulted in a series of rules and regulations by the SEC that increase responsibilities and liabilities of directors and executive officers. The perceived increased personal risk associated with these recent changes may deter qualified individuals from accepting these roles. As a result, it may be more difficult for us to attract and retain qualified persons to serve on our board of directors or as executive officers. We continue to evaluate and monitor developments with respect to these rules, and we cannot predict or estimate the amount of additional costs we may incur or the timing of such costs.

Risks Related to Our Securities

If a market for our common stock does not develop, shareholders may be unable to sell their shares.

We are quoted on the OTCBB under the symbol “WDST” but do not currently have an active trading market. If a public market for our common stock does not develop, investors may not be able to re-sell the shares of our common stock that they have purchased and may lose all of their investment.

If the selling shareholders sell a large number of shares all at once or in blocks, the market price of our shares would most likely decline.

The selling shareholders are offering 925,000 shares of our common stock through this prospectus. The outstanding shares of common stock covered by this prospectus represent approximately 44.2% of the common shares outstanding as of the date of this prospectus. Should a market develop, shares sold at a price below the current market price at which the common stock is trading will cause that market price to decline. Moreover, the offer or sale of a large number of shares at any price may cause the market price to fall.

If we issue shares of preferred stock with superior rights than the common stock registered in this prospectus, it could result in a decrease in the value of our common stock and delay or prevent a change in control of us.

Our board of directors is authorized to issue up to 10,000,000 shares of preferred stock. Our board of directors has the power to establish the dividend rates, liquidation preferences, voting rights, redemption and conversion terms and privileges with respect to any series of preferred stock. The issuance of any shares of preferred stock having rights superior to those of the common stock may result in a decrease in the value or market price of the common stock. Holders of preferred stock may have the right to receive dividends, certain preferences in liquidation and conversion rights.

The issuance of preferred stock could, under certain circumstances, have the effect of delaying, deferring or preventing a change in control of us without further vote or action by the stockholders and may adversely affect the voting and other rights of the holders of common stock.

If a public market for our common stock develops, short selling could increase the volatility of our stock price.

Short selling occurs when a person sells shares of stock which the person does not yet own and promises to buy stock in the future to cover the sale. The general objective of the person selling the shares short is to make a profit by buying the shares later, at a lower price, to cover the sale. Significant amounts of short selling, or the perception that a significant amount of short sales could occur, could depress the market price of our common stock. In contrast, purchases to cover a short position may have the effect of preventing or retarding a decline in the market price of our common stock, and together with the imposition of the penalty bid, may stabilize, maintain or otherwise affect the market price of our common stock. As a result, the price of our common stock may be higher than the price that otherwise might exist in the open market. If these activities are commenced, they may be discontinued at any time. These transactions may be effected on over-the-counter bulletin board or any other available markets or exchanges. Such short selling if it were to occur could impact the value of our stock in an extreme and volatile manner to the detriment of our shareholders.

Because we do not expect to pay dividends for the foreseeable future, investors seeking cash dividends should not purchase our common stock.

We have never declared or paid any cash dividends on our common stock. We currently intend to retain future earnings, if any, to finance the expansion of our business. As a result, we do not anticipate paying any cash dividends in the foreseeable future. Our payment of any future dividends will be at the discretion of our board of directors after taking into account various factors, including but not limited to our financial condition, operating results, cash needs, growth plans and the terms of any credit agreements that we may be a party to at the time. Accordingly, investors must rely on sales of their own common stock after price appreciation, which may never occur, as the only way to realize their investment. Investors seeking cash dividends should not purchase our common stock.

Because we will be subject to the “Penny Stock” rules once our shares are quoted on the over-the-counter bulletin board, the level of trading activity in our stock may be reduced.

Broker-dealer practices in connection with transactions in “penny stocks” are regulated by penny stock rules adopted by the Securities and Exchange Commission. Penny stocks generally are equity securities with a price of less than \$5.00 (other than securities registered on some national securities exchanges or quoted on Nasdaq). The penny stock rules require a broker-dealer, prior to a transaction in a penny stock not otherwise exempt from the rules, to deliver a standardized risk disclosure document that provides information about penny stocks and the nature and level of risks in the penny stock market. The broker-dealer also must provide the customer with current bid and offer quotations for the penny stock, the compensation of the broker-dealer and its salesperson in

the transaction, and, if the broker-dealer is the sole market maker, the broker-dealer must disclose this fact and the broker-dealer's presumed control over the market, and monthly account statements showing the market value of each penny stock held in the customer's account. In addition, broker-dealers who sell these securities to persons other than established customers and "accredited investors" must make a special written determination that the penny stock is a suitable investment for the purchaser and receive the purchaser's written agreement to the transaction. Consequently, these requirements may have the effect of reducing the level of trading activity, if any, in the secondary market for a security subject to the penny stock rules, and investors in our common stock may find it difficult to sell their shares.

Forward-Looking Statements

This prospectus contains forward-looking statements that involve risks and uncertainties. We use words such as anticipate, believe, plan, expect, future, intend and similar expressions to identify such forward-looking statements. The actual results could differ materially from our forward-looking statements. Our actual results are most likely to differ materially from those anticipated in these forward-looking statements for many reasons, including the risks faced by us described in this Risk Factors section and elsewhere in this prospectus.

Use of Proceeds

We will not receive any proceeds from the sale of the common stock offered through this prospectus by the selling shareholders.

Determination of Offering Price

The \$0.02 per share offering price of our common stock was arbitrarily chosen using the last sales price of our stock from our most recent private offering of common stock. There is no relationship between this price and our assets, earnings, book value or any other objective criteria of value.

We are quoted on the OTCBB under the symbol "WDST" but do not currently have an active trading market. If our common stock becomes so traded and a market for the stock develops, the actual price of stock will be determined by prevailing market prices at the time of sale or by private transactions negotiated by the selling shareholders. The offering price would thus be determined by market factors and the independent decisions of the selling shareholders.

Dilution

The common stock to be sold by the selling shareholders is common stock that is currently issued and outstanding. Accordingly, there will be no dilution to our existing shareholders.

Selling Shareholders

The selling shareholders named in this prospectus are offering all of the 925,000 shares of common stock offered through this prospectus. These shares were acquired from us in an offering that was exempt from Registration under Regulation S of the Securities Act of 1933, as amended, and completed on September 6, 2007.

The following table provides information regarding the beneficial ownership of our common stock held by each of the selling shareholders as of March 17, 2010, including:

1. the number of shares owned by each prior to this offering;
2. the total number of shares that are to be offered by each;
3. the total number of shares that will be owned by each upon completion of the offering;
4. the percentage owned by each upon completion of the offering; and
5. the identity of the beneficial holder of any entity that owns the shares.

The named parties beneficially own and have sole voting and investment power over all shares or rights to the shares, unless otherwise shown in the table. The numbers in this table assume that none of the selling shareholders sells shares of common stock not being offered in this prospectus or purchases additional shares of common stock, and assumes that all shares offered are sold. The percentages are based on 2,150,000 shares of common stock outstanding on March 17, 2010.

Name and Address of Selling Shareholder	Shares Owned Prior to This Offering	Total Number of Shares to be Offered for Selling Shareholder Account	Total Shares to be Owned Upon Completion of this Offering	Percent Owned Upon Completion of this Offering
Kanaga Durga A/P Bakthvathsulu Z-2, Taman Banboo Jalan Terolak 3, Batu 4 ¼, Jalan Ipoh, 51200 Kuala Lumpur	25,000	25,000	0	0
Mohd Rasidi Bin Mustafa No.317, Jalan Puyuh, Batu 9 ½, Jalan Cheras 43200 Selangor	25,000	25,000	0	0
Cheong Poh Yoke No. 1493, Jalan Jiran 8, Happy Garden, 58200 Kuala Lumpur	25,000	25,000	0	0
Mohd Shahbini Bin Selamat No.48, Jalan Kasturi 40, Seksyen Bb8, Bandar Baru Bukit Beruntung, 48300 Rawang Selangor	25,000	25,000	0	0
Ahmad Daud Bin Alwi No.3, Jalan Ros 2a/7, Seksyen Bs 5, Bukit Sentosa, 48300 Rawang Selangor	25,000	25,000	0	0
Mohamed Noor Hisham Bin Osman No. 14, Jalan Suadamai 4/1a, Bandar Tun Hussein Onn, 43200 Batu 9 Cheras, Selangor	25,000	25,000	0	0
Zulkiflee Bin Mohd Rani No.32, Jalan 7/17, Bandar Tasik Puteri, 48020 Rawang Selangor	25,000	25,000	0	0
Norhayati Binti Mohammad Lot 5002, Batu 5 1/2, Jalan Meru, Kalang 41050 Selangor	25,000	25,000	0	0
Diharno Bin Johari Blok C-2-13 Apartmen Mawar, Jalan Bunga Raya 2, Taman Bunga Raya, Bukit Beruntung 48300 Rawang Selangor	25,000	25,000	0	0
Ainel Daina Binti Mohd Jonid No.9, Jalan Desa 2/3, Country	25,000	25,000	0	0

Homes, Rawang 48000, Selangor				
Norazmi Binti Mohd Jonid				
Batu 9, Jalan Klang Lama, Peti Surat 6503, Seri Setia, Petaling Jaya 47307 Selangor	25,000	25,000	0	0
Abdul Khalim Bin Jumli				
No.128, Jalan 4, Taman Desa Damai, 28700 Bentong, Pahang	25,000	25,000	0	0
Ros Timah Binti Mat Yunan				
Kampung Pamah Rawas, Ulu Dong 27600 Raub, Pahang	25,000	25,000	0	0
Amin Bin Ibrahim				
No.1, Jalan Ss 17/3c, 47500 Subang Jaya, Selangor	25,000	25,000	0	0
Lim Chew Ting				
No.4, Jalan 1, Kampung Baru, Sungai Chua, 43000 Kajang, Selangor	25,000	25,000	0	0
Stonton Morse Anak Jerry				
Rumpang				
No.1, Morse's Residence, Jalan Airport, 95000 Sri Aman, Sarawak	25,000	25,000	0	0
Abdul Rauf Bin Jamaludin				
No.141, Jalan Abdul Rahman, Perumahan Melayu, Kampung Baru, 28700 Bentong, Pahang	25,000	25,000	0	0
Ahmad Daud Bin Mohd Noor				
No.282, Jalan Utama, Taman Desa Damai, 28700 Bentong, Pahang	25,000	25,000	0	0
Mohamad Nazar Bin Zakaria				
Km 4 1/2, Kampung Pangsenam, 28000 Temerloh, Pahang	25,000	25,000	0	0
Pragalath Kumar A/L Kumaran				
No.16, Jalan 4a, Desa Sri Jenaris, 43000 Kajang, Selangor	25,000	25,000	0	0
Sin Yew Hoong				
No.31, Jalan Usj 2/5e, Uep Subang Jaya, 47600 Subang Jaya, Selangor	25,000	25,000	0	0
Lim Mei Ee				
No.5b-1004, Blok B, Emeral Hill Condo, Bukit Indah, 68000 Ampang, Selangor	25,000	25,000	0	0
Chai Pei Shen				
No.55, Jalan Wangsa 1/1, Taman Wangsa Permai, Kepong 52100 Kuala Lumpur	25,000	25,000	0	0
Wee Joo Han				
355-D, Jalan Temenggong, 15000 Kota Bharu, Kelantan	25,000	25,000	0	0
Romle Bin Jamran				
No.101, Perumahan Lknp, Kampung Muhibbah, Benus, 28700 Bentong, Pahang	25,000	25,000	0	0
Mohamad Azmi Bin Rahmat				
Lot 2058, Jalan Tengah, Kampung Sri Pantai, 86800 Mersing, Johor	25,000	25,000	0	0
Hooi Kin Kok				
No.23, Jalan Tokong, Jelapang, 30020 Ipoh, Perak	25,000	25,000	0	0

Norhazilah Binti Ahmad

No.243, Taman Long Jaffar Fasa 3/12, 34000 Taiping, Perak	25,000	25,000	0	0
Khor Kin Leong No.31, Jalan Sri Melati 16, Taman Sri Melati, 68100 Batu Caves, Selangor	25,000	25,000	0	0
Low Kah Soon No.13, Jalan Tekukor, Off Jalan Ipoh Batu 3, 51200 Kuala Lumpur	25,000	25,000	0	0
Wong Kong Fong No.4, Jalan Angsana 2/2g, Sri Damansara, Kepong, 52100 Kuala Lumpur	25,000	25,000	0	0
Lau Eng Bok No.43, Jalan 12/18a, Taman Mastiara, Batu 6, Jalan Ipoh, 51200 Kuala Lumpur	25,000	25,000	0	0
Chin Pui Kwong No.23, Jalan 2/37b, Taman Bukit Maluri, Kepong, 52100 Kuala Lumpur	25,000	25,000	0	0
Francis A/L Moses No.9, Jalan Indah 5, Taman Medan Indah, 27600 Raub, Pahang	25,000	25,000	0	0
Lee Wan Yuen No.39, Jalan Mewah 2/1, Pandan Mewah, 68000 Ampang, Selangor	25,000	25,000	0	0
Siow Chun Leng No.39, Cp 7/66, Taman Cheras Paerdana, 43200 Batu 9 Cheras, Selangor	25,000	25,000	0	0
Pong Wai Ling No.695-24-05, Desa Kiara Condo, Jalan Damansara, 60000 Kuala Lumpur	25,000	25,000	0	0

None of the selling shareholders; (1) has had a material relationship with us other than as a shareholder at any time within the past three years; (2) has been one of our officers or directors; or (3) are broker-dealers or affiliate of broker-dealers.

The selling shareholders and any broker/dealers who act in connection with the sale of the shares may be deemed to be “underwriters” within the meaning of the Securities Acts of 1933, and any commissions received by them and any profit on any resale of the shares as a principal might be deemed to be underwriting discounts and commissions under the Securities Act.

Plan of Distribution

The selling shareholders may sell some or all of their common stock in one or more transactions, including block transactions:

1. on such public markets or exchanges as the common stock may from time to time be trading;
2. in privately negotiated transactions;
3. through the writing of options on the common stock;
4. in short sales, or;
5. in any combination of these methods of distribution.

We are quoted on the OTCBB under the symbol “WDST” but do not currently have an active trading market. If our common stock becomes actively traded on the OTCBB, or another exchange, then the sales price to the public will vary according to the selling decisions of each selling shareholder and the market for our stock at the time of resale. In these circumstances, the sales price to the public may be:

1. the market price of our common stock prevailing at the time of sale;
2. a price related to such prevailing market price of our common stock, or;
3. such other price as the selling shareholders determine from time to time.

The shares may also be sold in compliance with the Securities and Exchange Commission's Rule 144.

The selling shareholders may also sell their shares directly to market makers acting as agents in unsolicited brokerage transactions. Any broker or dealer participating in such transactions as an agent may receive a commission from the selling shareholders or from such purchaser if they act as agent for the purchaser. If applicable, the selling shareholders may distribute shares to one or more of their partners who are unaffiliated with us. Such partners may, in turn, distribute such shares as described above.

We are bearing all costs relating to the registration of the common stock. The selling shareholders, however, will pay any commissions or other fees payable to brokers or dealers in connection with any sale of the common stock.

The selling shareholders must comply with the requirements of the Securities Act of 1933 and the Securities Exchange Act in the offer and sale of the common stock. In particular, during such times as the selling shareholders may be deemed to be engaged in a distribution of the common stock, and therefore be considered to be an underwriter, they must comply with applicable law and may, among other things:

1. not engage in any stabilization activities in connection with our common stock;
2. furnish each broker or dealer through which common stock may be offered, such copies of this prospectus, as amended from time to time, as may be required by such broker or dealer; and;
3. not bid for or purchase any of our securities or attempt to induce any person to purchase any of our securities other than as permitted under the Securities Exchange Act.

Legal Proceedings

We are not currently a party to any legal proceedings.

Directors, Executive Officers, Promoters and Control Persons

Our executive officers and directors and their respective ages as of March 17, 2010 are as follows:

Name	Age	Position Held with the Company
Siew Mee Fam No 47 Hala Pegoh, 8 Taman Sri Pengkalan 31650 Ipoh, Perak, Malaysia	28	President, Chief Executive Officer, Principal Executive Officer, Chief Financial Officer, Principal Financial Officer, Principal Accounting Officer and Director
Sze Yein Wong No 47 Hala Pegoh, 8 Taman Sri Pengkalan 31650 Ipoh, Perak, Malaysia	28	Director

Set forth below is a brief description of the background and business experience of our sole executive officer and directors.

Siew Mee Fam is our President, Chief Executive Officer, Principal Executive Officer, Chief Financial Officer, Principal Financial Officer, Principal Accounting Officer and Director. Siew Mee Fam obtained a Bachelor of Arts from HELP University College in Pusat Bandar Damansara, Malaysia in March of 2002, and has worked as a Public Relations Specialist for Salient Synergy Sdn. Bhd. since 2002.

Sze Yein Wong is one of our directors. Siew Mee Fam obtained a Bachelor of Science Degree from Universiti Putra Malaysia (UPM), Serdang in April of 2002, and has worked as an Engineer for General Electric, Inc. since 2002.

Term of Office

Our Directors are appointed for a one-year term to hold office until the next annual general meeting of our shareholders or until removed from office in accordance with our bylaws. Our officers are appointed by our board of directors and hold office until removed by the board.

Significant Employees

We do not currently have any significant employees aside from Siew Mee Fam and Sze Yein Wong.

Involvement in Certain Legal Proceedings

To the best of our knowledge, during the past five years, none of the following occurred with respect to our present or former director, executive officer, or employee: (1) any bankruptcy petition filed by or against any business of which such person was a general partner or executive officer either at the time of the bankruptcy or within two years prior to that time; (2) any conviction in a criminal proceeding or being subject to a pending criminal proceeding (excluding traffic violations and other minor offenses); (3) being subject to any order, judgment or decree, not subsequently reversed, suspended or vacated, of any court of competent jurisdiction, permanently or temporarily enjoining, barring, suspending or otherwise limiting his or her involvement in any type of business, securities or banking activities; and (4) being found by a court of competent jurisdiction (in a civil action), the SEC or the Commodities Futures Trading Commission to have violated a federal or state securities or commodities law, and the judgment has not been reversed, suspended or vacated.

Committees of the Board

Our company currently does not have nominating, compensation or audit committees or committees performing similar functions nor does our company have a written nominating, compensation or audit committee charter. Our directors believe that it is not necessary to have such committees, at this time, because the functions of such committees can be adequately performed by the board of directors.

Our company does not have any defined policy or procedural requirements for shareholders to submit recommendations or nominations for directors. The board of directors believes that, given the stage of our development, a specific nominating policy would be premature and of little assistance until our business operations develop to a more advanced level. Our company does not currently have any specific or minimum criteria for the election of nominees to the board of directors and we do not have any specific process or procedure for evaluating such nominees. The board of directors will assess all candidates, whether submitted by management or shareholders, and make recommendations for election or appointment.

A shareholder who wishes to communicate with our board of directors may do so by directing a written request addressed to our President and director, Siew Mee Fam, at the address appearing on the first page of this annual report.

Code of Ethics

As of December 31 , 2009, we had not adopted a Code of Ethics for Financial Executives, which would include our principal executive officer, principal financial officer, principal accounting officer or controller, or persons performing similar functions.

Security Ownership of Certain Beneficial Owners and Management

The following table sets forth, as of September 30, 2009, certain information as to shares of our common stock owned by (i) each person known by us to beneficially own more than 5% of our outstanding common stock, (ii) each of our directors, and (iii) all of our executive officers and directors as a group:

Name and Address of Beneficial Owners of Common Stock	Title of Class	Amount and Nature of Beneficial Ownership ¹	% of Common Stock ₂
Siew Mee Fam No 47 Hala Pegoh, No 47 Hala Pegoh, 8 Taman Sri Pengkalan 31650 Ipoh, Perak, Malaysia	Common Stock	600,000	27.9%
Sze Yein Wong No 47 Hala Pegoh, 8 Taman Sri Pengkalan 31650 Ipoh, Perak, Malaysia	Common Stock	600,000	27.9%
DIRECTORS AND OFFICERS – TOTAL		1,200,000	55.8%
5% SHAREHOLDERS			
NONE	Common Stock	NONE	NONE

- As used in this table, "beneficial ownership" means the sole or shared power to vote, or to direct the voting of, a security, or the sole or shared investment power with respect to a security (i.e., the power to dispose of, or to direct the disposition of, a security). In addition, for purposes of this table, a person is deemed, as of any date, to have "beneficial ownership" of any security that such person has the right to acquire within 60 days after such date.
- The percentage shown is based on denominator of 2,150,000 shares of common stock issued and outstanding for the company as of September 30, 2009.

Description of Securities

Our authorized capital stock consists of 90,000,000 shares of common stock, with a par value of \$0.001 per share, and 10,000,000 shares of preferred stock, with a par value of \$0.001 per share. As of September 30 2009, there were 2,150,000 shares of our common stock issued and outstanding. Our shares are held by forty (40) stockholders of record. We have not issued any shares of preferred stock.

Common Stock

Our common stock is entitled to one vote per share on all matters submitted to a vote of the stockholders, including the election of directors. Except as otherwise required by law or provided in any resolution adopted by our board of directors with respect to any series of preferred stock, the holders of our common stock will possess all voting power. Generally, all matters to be voted on by stockholders must be approved by a majority (or, in the case of election of directors, by a plurality) of the votes entitled to be cast by all shares of our common stock that are present in person or represented by proxy, subject to any voting rights granted to holders of any preferred stock. Holders of our common stock representing fifty percent (50%) of our capital stock issued, outstanding and entitled to vote, represented in person or by proxy, are necessary to constitute a quorum at any meeting of our stockholders. A vote by the holders of a majority of our outstanding shares is required to effectuate certain fundamental corporate changes such as liquidation, merger or an amendment to our Articles of Incorporation. Our Articles of Incorporation do not provide for cumulative voting in the election of directors.

Subject to any preferential rights of any outstanding series of preferred stock created by our board of directors from time to time, the holders of shares of our common stock will be entitled to such cash dividends as may be declared from time to time by our board of directors from funds available therefore.

Subject to any preferential rights of any outstanding series of preferred stock created from time to time by our board of directors, upon liquidation, dissolution or winding up, the holders of shares of our common stock will be entitled to receive pro rata all assets available for distribution to such holders.

In the event of any merger or consolidation with or into another company in connection with which shares of our common stock are converted into or exchangeable for shares of stock, other securities or property (including cash), all holders of our common stock will be entitled to receive the same kind and amount of shares of stock and other securities and property (including cash). Holders of our common stock have no pre-emptive rights, no conversion rights and there are no redemption provisions applicable to our common stock.

Preferred Stock

Our board of directors is authorized by our articles of incorporation to divide the authorized shares of our preferred stock into one or more series, each of which must be so designated as to distinguish the shares of each series of preferred stock from the shares of all other series and classes. Our board of directors is authorized, within any limitations prescribed by law and our articles of incorporation, to fix and determine the designations, rights, qualifications, preferences, limitations and terms of the shares of any series of preferred stock including, but not limited to, the following:

1. The number of shares constituting that series and the distinctive designation of that series, which may be by distinguishing number, letter or title;
2. The dividend rate on the shares of that series, whether dividends will be cumulative, and if so, from which date(s), and the relative rights of priority, if any, of payment of dividends on shares of that series;
3. Whether that series will have voting rights, in addition to the voting rights provided by law, and, if so, the terms of such voting rights;
4. Whether that series will have conversion privileges, and, if so, the terms and conditions of such conversion, including provision for adjustment of the conversion rate in such events as the Board of Directors determines;
5. Whether or not the shares of that series will be redeemable, and, if so, the terms and conditions of such redemption, including the date or date upon or after which they are redeemable, and the amount per share payable in case of redemption, which amount may vary under different conditions and at different redemption dates;
6. Whether that series will have a sinking fund for the redemption or purchase of shares of that series, and, if so, the terms and amount of such sinking fund;
7. The rights of the shares of that series in the event of voluntary or involuntary liquidation, dissolution or winding up of the corporation, and the relative rights of priority, if any, of payment of shares of that series;
8. Any other relative rights, preferences and limitations of that series.

Provisions in Our Articles of Incorporation and By-Laws That Would Delay, Defer or Prevent a Change in Control

Our articles of incorporation authorize our board of directors to issue a class of preferred stock commonly known as a "blank check" preferred stock. Specifically, the preferred stock may be issued from time to time by the board of directors as shares of one (1) or more classes or series. Our board of directors, subject to the provisions of our Articles of Incorporation and limitations imposed by law, is authorized to adopt resolutions; to issue the shares; to fix the number of shares; to change the number of shares constituting any series; and to provide for or change the following: the voting powers; designations; preferences; and relative, participating, optional or other special rights, qualifications, limitations or restrictions, including the following: dividend rights, including whether dividends are cumulative; dividend rates; terms of redemption, including sinking fund provisions; redemption prices; conversion rights and liquidation preferences of the shares constituting any class or series of the preferred stock.

In each such case, we will not need any further action or vote by our shareholders. One of the effects of undesignated preferred stock may be to enable the board of directors to render more difficult or to discourage an attempt to obtain control of us by means of a tender offer, proxy contest, merger or otherwise, and thereby to protect the continuity of our management. The issuance of shares of preferred stock pursuant to the board of director's authority described above may adversely affect the rights of holders of common stock. For example, preferred stock issued by us may rank prior to the common stock as to dividend rights, liquidation preference or both, may have full or limited voting rights and may be convertible into shares of common stock. Accordingly, the issuance of shares of preferred stock may discourage bids for the common stock at a premium or may otherwise adversely affect the market price of the common stock.

Dividend Policy

We have never declared or paid any cash dividends on our common stock. We currently intend to retain future earnings, if any, to finance the expansion of our business. As a result, we do not anticipate paying any cash dividends in the foreseeable future.

Share Purchase Warrants

We have not issued and do not have outstanding any warrants to purchase shares of our common stock.

Options

We have not issued and do not have outstanding any options to purchase shares of our common stock.

Convertible Securities

We have not issued and do not have outstanding any securities convertible into shares of our common stock or any rights convertible or exchangeable into shares of our common stock.

Nevada Anti-Takeover Laws

Nevada Revised Statutes sections 78.378 to 78.379 provide state regulation over the acquisition of a controlling interest in certain Nevada corporations unless the articles of incorporation or bylaws of the corporation provide that the provisions of these sections do not apply. Our articles of incorporation and bylaws do not state that these provisions do not apply. The statute creates a number of restrictions on the ability of a person or entity to acquire control of a Nevada company by setting down certain rules of conduct and voting restrictions in any acquisition attempt, among other things. The statute is limited to corporations that are organized in the state of Nevada and that have 200 or more stockholders, at least 100 of whom are stockholders of record and residents of the State of Nevada; and does business in the State of Nevada directly or through an affiliated corporation. Because of these conditions, the statute currently does not apply to our company.

Interests of Named Experts and Counsel

No expert or counsel named in this prospectus as having prepared or certified any part of this prospectus or having given an opinion upon the validity of the securities being registered or upon other legal matters in connection with the registration or offering of the common stock was employed on a contingency basis, or had, or is to receive, in connection with the offering, a substantial interest, direct or indirect, in the registrant or any of its parents or subsidiaries. Nor was any such person connected with the registrant or any of its parents or subsidiaries as a promoter, managing or principal underwriter, voting trustee, director, officer, or employee.

David S. Jennings, Esq., our independent legal counsel, has provided an opinion on the validity of our common stock.

Maddox Ungar Silberstein, PLLC, has audited our financial statements included in this prospectus and registration statement to the extent and for the periods set forth in his audit report. Silberstein Ungar, PLLC (formerly known as Maddox Ungar Silberstein, PLLC) has presented his report with respect to our audited financial statements. The report of [Silberstein Ungar, PLLC \(formerly known as Maddox Ungar Silberstein, PLLC\)](#) is included in reliance upon his authority as an expert in accounting and auditing.

Disclosure of Commission Position of Indemnification for Securities Act Liabilities

Our articles of incorporation provide that we will indemnify an officer, director, or former officer or director, to the full extent permitted by law. We have been advised that in the opinion of the Securities and Exchange Commission indemnification for liabilities arising under the Securities Act of 1933 is against public policy as expressed in the Securities Act of 1933, and is, therefore, unenforceable. In the event that a claim for indemnification against such liabilities is asserted by one of our directors, officers, or controlling persons in connection with the securities being registered, we will, unless in the opinion of our legal counsel the matter has been settled by controlling precedent, submit the question of whether such indemnification is against public policy to a court of appropriate jurisdiction. We will then be governed by the court's decision.

Organization within the Last Five Years

We were incorporated as “Windstar, Inc.” in the State of Nevada on September 6, 2007. We are engaged in the business of developing, producing, and marketing an effective and inexpensive air purification device.

Our principal executive offices are located at 50 West Liberty Street, Suite 880, Reno, NV 89501. Our telephone number is (014) 327-4470. Our operations office is located at No. 47 Hala Pegoh, 8 Taman Sri Pengkalan 31650, Ipoh, Perak, Malaysia.

Our fiscal year end is September 30. Siew Mee Fam, our officer and director, and Sze Yein Wong, our director, may be described as a “promoters” as defined in Rule 405 of the Securities Act by virtue of his role in founding and organizing our company.

Description of Business

Company Overview

We were incorporated as “Windstar, Inc.” in the State of Nevada on September 6, 2007. We are engaged in the business of developing, producing, and marketing an effective and inexpensive air purification device.

Our goal is to produce an improved air purification device (our “Product”) specifically for removing the impurities produced while cooking, and for recycling and redistributing the cleansed air back into the kitchen. Our intention is to manufacture and distribute our Product to residential consumers in the Philippines and other Asian countries for everyday use in their homes.

We are a development stage company and have not generated any sales to date. Our product is still in the development stage and is not yet ready for commercial sale. We plan to complete the development of our product in the next six to twelve months, and begin recognizing revenue from the distribution of our product by April, 2011.

The Market for our Product

In many Asian countries, the standard of living has been steadily increasing for the average citizen as a result of recent economic and political stability. As a result, more families are enjoying the benefits of single residence homes, many of which include a separate kitchen area for food preparation. Although the standard of living has been rising, most Asian families still rely on traditional dietary staples (fried rice, vegetables and various cuts of meat) to feed their families. The preparation of these popular dietary choices historically involves the ingredients being fried in some type of cooking oil, either in a wok or a skillet, over a large stove-top flame.

The preparation of a typical Asian meal, particularly on a hot stove, produces an exorbitant amount of harsh airborne by-products that can adversely affect the air quality in the surrounding space, specifically the kitchen. Once infiltrated by these impurities, the kitchen air may contain large amounts of particulate-laden steam, smoke, fats, oils, noxious odors and other chemicals.

We have reviewed current air purification systems available in Asia markets, with the exception of Japan, in which we do not intend to operate. Most Asian kitchens are equipped with a single fan, usually stationed above the stove area, to remove any smoke and impurities created in the cooking process. These fans, however, are largely ineffective and do little more than recirculate the polluted air. Fans are not effective at improving the overall air quality in the room, nor do they reduce any distasteful odors that may be produced while cooking. Most specialized air purification systems available in Asia require the installation of expensive systems of fans, vents, and filters throughout the kitchen, which is inconvenient and impractical for residential consumers. Other self-contained purification products similar to ours are only effective at removing one or two contaminants from the air, and do not address the wide variety of impurities and odors created by cooking. Our product uses a myriad of filters and methods for removing particulate matter, reducing odors, and cleansing the air.

Air Purification Methods

There are two main methods for disposing of the impurities that commonly infiltrate the air during cooking. The first type of system simply removes the impure air from the kitchen and transports it through vents for release into the atmosphere. However, venting the impure air to the outside requires the installation of an expensive and cumbersome system of filters and vents, which is not a practical solution for most residential kitchens. Additionally, it is believed that releasing the impure air to the atmosphere can decrease air quality in the immediate vicinity, which is inconvenient and may even be restricted in some areas.

The second type of air purification system suctions the impure air, cleanses it, and then returns it to the kitchen in a cyclical process. This system only requires the installation of a single, self-contained air purification device in the kitchen area, where the air is most likely to be affected by cooking by-products. We have focused the development of our Product on this system because it is simple, practical, and cost-effective for the residential consumer.

Among the systems that cleanse and recycle the air, several different processes of varying effectiveness can be used for air purification. Most of the processes are effective at cleansing the air of a particular contaminant. The most commonly used processes are:

- 1) **Filter-based** . A filter based purification system suctions the impure air and forces it through a filter to physically trap airborne particles. Most filters are effective at trapping all particulates that are larger than a particular size. For example, HEPA (High Efficiency Particulate Air) filters are most effective at trapping particles that are 0.3 micrometers in size or larger. Some more advance HEPA filters may even trap particles as small as 0.01 micrometers.
- 2) **Activated Carbon.** Activated carbon is a highly porous material that can absorb volatile chemicals on a molecular basis, and is effective at removing volatile organic compounds, chemicals and strong odors from the air. Activated carbon can be used alone or in conjunction with other filter technology.
- 3) **Ionization.** Ionizer purifiers use charged electrical surfaces to generate electrically charged ions. These ions attach to airborne particles which are then electrostatically attracted to a charged collector plate, thus removing the pollutants from the air.

Our Product

We are in the process of developing an air purification device that is both easily manufactured and very effective at cleansing the impure air that results from cooking in home kitchens. Once completed, we believe our Product will be particularly useful for cleansing the air of odors, smoke, particulates, and other by-products of Asian-style cooking techniques employed with stoves, ovens, or indoor grilles.

Since our inception, we have been attempting to raise money to complete our Product, but have not been able to secure the funds necessary to do so. We had hoped to secure the funds and initially projected April of 2009 as a reasonable date to start realizing revenue from a completed Product. The lack of funds and the present economy have prevented that from happened. We will need to raise capital to implement to develop and successfully market our Product.

Our Product is a self-contained air purification system that utilizes a four-stage process to remove particulate matter, decrease smoke vapors, and cut down on noxious odors created by common Asian cooking methods. Our Product differs from others currently available in the market because the four-stage process allows for the optimum removal of an array of contaminants, including particulate matter, heavy smoke, and odors, as follows:

- 1) Air initially passes through the first stage of our air purification system, which is a filter net, designed to trap particulate matter as small as 0.3 micrometers, in much the same way and to a similar degree as a HEPA filter. Our system uses an updraft vent to collect the impure air and force it into our filtration device. We are currently investigating the incorporation of a fan to draw the impure air into our Product. We will assess the advantages, such as increased volume and efficiency, and disadvantages, such as increased noise, required power to operate, and expense to manufacture, before deciding if a fan-based system is warranted.
- 2) In the second stage of our system filtered air is passed through an ionization unit. Here the air will be further purified of particulate matter by using electrically charged ions to attract airborne particles and trap them on a charged electrical surface.

- 3) The third stage of our system is an oil collection device, which removes heavy grease and oil particles that are produced by cooking fatty foods over high flames, and collects the substances in a special collection tray, which can be easily removed, cleaned, or replaced as necessary.
- 4) The fourth and final stage of our system is an activated carbon filter, which rids the air of odors by absorbing any remaining volatile compounds on a molecular level.

As air flows through our Product, it is filtered and purified multiple times, using a variety of methods to remove as many contaminants as possible before recirculating the recycled air back into the kitchen.

A distinct benefit of our Product is that the filters essential to each stage of purification are contained separately within the unit in special filtration “drawers,” which are easy to access. This gives the consumer the ability to remove the filtration units individually to clean or replace them without needing to remove or replace the entire unit. The diagram below illustrates the Product and its component pieces.

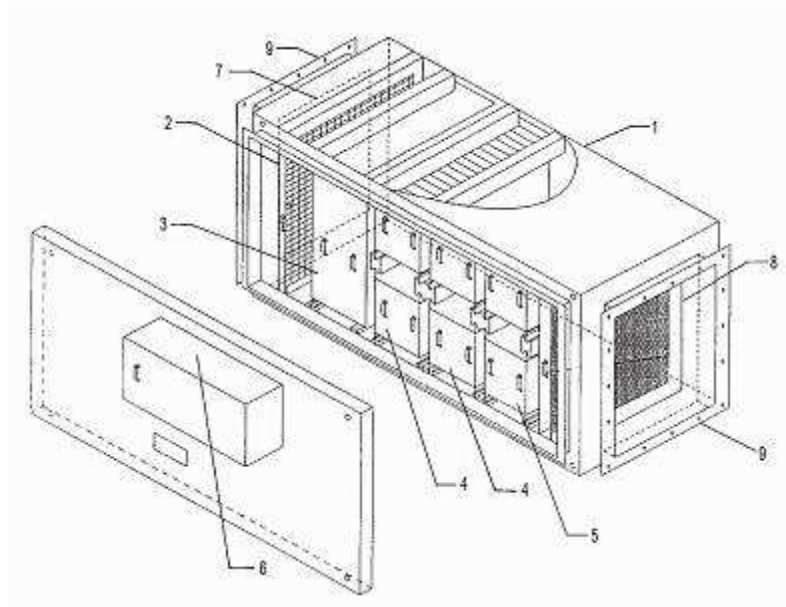

Diagram 1

1. Case
2. Filter Unit
3. Ionization Unit
4. Oil Collectors
5. Activated Carbon Unit
6. Power Supply
7. Air Inlet Port
8. Air Outlet (Exhaust) Port
9. Smoke Pipe Connectors

Competition

We face some competition in the development, production, and marketing of air filtration devices. Other companies in this field are established manufacturers who sell air filtration devices in many countries around the world. These companies enjoy brand recognition which exceeds that of our brand name. We compete with several manufacturers, importers and distributors who have significantly greater financial, distribution, advertising and marketing resources than we do. We intend to compete primarily on the basis of quality, brand name recognition and price. Also, we are developing our Product specifically for homeowners in the Philippines and other Asian countries

We believe that our success will depend upon our ability to remain competitive in our product area. The failure to compete successfully in the future could result in a material deterioration of customer loyalty and our image and could have a material adverse effect on our business.

Intellectual Property

We intend to aggressively assert our rights under trade secret, unfair competition, trademark and copyright laws in the Philippines and the Asian countries in which we plan to do business to protect our intellectual property, including product formulas, proprietary manufacturing processes and technologies, product research and concepts and recognized trademarks. These rights are protected through the acquisition of patents and trademark registrations, the maintenance of trade secrets, the development of trade dress, and, where appropriate, litigation against those who are, in our opinion, infringing these rights.

Brand Recognition

We have selected the name of our company in an attempt to establish our brand name. Although our name and logo are not trademarked at this time, we anticipate the necessity of a trademark upon successful commercialization of our Product in order to protect our brand integrity.

Patents

We are in the process of researching patent rights, and at present we are not aware of anyone in Asia or the Phillipines having any patents, trademarks and/or copyright protection for this or any similar product. Upon successful completion of the development of our Product, we plan to apply for patent protection and/or copyright protection in the Phillipines, and other jurisdictions in which we conduct business and distribute our product.

Government Regulation and Supervision

We are subject to the laws and regulations of those jurisdictions in which we plan to sell our product, which are generally applicable to business operations, such as business licensing requirements, income taxes and payroll taxes. In general, the sale of our product in the Philippines is not subject to special regulatory and/or supervisory requirements.

Employees

We have no other employees other than our officers and directors. If finances permit, however, we intend on employing sales representatives in the Philippines when our product is ready for production and shipping.

Description of Property

Our operations office is located at No. 47 Hala Pegoh, 8 Taman Sri Pengkalan 31650, Ipoh, Perak, Malaysia. We do not lease or own any real property. Our offices are provided free of charge by Siew Mee Fam, our officer and director.

Management's Discussion and Analysis of Financial Condition and Results of Operations

This prospectus contains forward-looking statements that involve risks and uncertainties. Readers are cautioned not to place undue reliance on these forward-looking statements, which speak only as of the date that they are made. We undertake no obligation to publicly update or revise any forward-looking statements, whether as a result of new information, future events or otherwise.

The following discussion should be read in conjunction with the financial statements and notes thereto included in this prospectus.

Plan of Operation in the Next Twelve Months

Product Development

Our company's goal is to produce an air purification device that is available to the public at a price of \$20 per unit, so as not to create a financial hardship on families who would like cleaner kitchen air. We will achieve this goal by continuing to develop our product using the best materials and methods available to achieve the highest quality product at the lowest possible production cost.

We intend to continue to test and refine the design of the prototype of our Product over the coming months. While we feel that our Product in its current form could compete effectively in the marketplace, we plan to improve the design of our Product to improve its filtration efficiency and reduce its production cost as much as possible. Specifically, we are looking to achieve the following:

- Creating the most effective purification system using the least amount of space;
- Making our product quieter and more energy efficient, to reduce consumer cost;
- Selecting the best materials available at the lowest cost possible

Depending upon the success of our initial product, in the future we intend to add additional components to give consumers more options and increase demand for our products. We expect to incur roughly \$10,000 on product development in the next twelve months.

Production and Distribution

We do not currently have any manufacturing facilities. Our directors have contacted several general manufacturers in the Philippines, and have begun negotiations for the manufacture of our product on a contract basis. We are currently negotiating price, payment, customer guarantee, shipping, inventory, delivery schedule and returns. Production of our Product doesn't require any facilities or equipment beyond what is available at any general manufacturer. We could contract with any general manufacturer to manufacture our product by following our instructions. Most manufacturers already utilize the same materials we use to create our Product, we simply need to provide the design and manufacturing instructions. We do not anticipate renting a warehouse at this stage of our business. The manufacturer we select to work with us will provide packaging, storage, and shipping services for us as part of our agreement.

We intend to sell our product in wholesale orders to large kitchen, home appliance, and residential construction companies. Upon receiving a wholesale order, we will arrange for manufacture and shipment of the Product to the customer at pre-negotiated prices from the manufacturer. We anticipate wholesale orders will be fulfilled within five business days of placing the order to the manufacturer. Our Product will arrive at the customer fully assembled, with easy-to-follow instructions for installation and use. As a result, production of our air purifiers will not require us to procure any special facilities or equipment.

Marketing Strategy

The goal of our company is for our air purification system to become the leading air purification product in Asia. In order to achieve our goal, we intend to complete the development of our initial product and introduce our product to the kitchen and home appliance industries within the next twelve months. To increase consumer awareness of our product among our potential customers, specifically major kitchen retailers, we intend to specifically engage in the following:

- Attending National and Regional Kitchen and Home Appliance Promotions, Events and Conferences : These are events and conferences managed by regional and central home appliance organizations to promote new kitchen products and technology. We plan to introduce our products to the home appliance merchants, retailers and wholesalers in attendance at these events. These events will also include trade meetings and promotional events and related seminars and conferences.
- Developing Direct Marketing Programs to Attract Retailers : We intend to market directly to retailers by conducting seminars, through the use of online advertisements, and through traditional media outlets such as newspapers and trade publications.
- Special Promotions : Initially, we intend to offer special promotions to a few major home appliance retailers by supplying them with a limited amount of our Product for sale or distribution to their general customers. Based on customer feedback, we anticipate these retailers will begin placing regular, wholesale orders with our company.

- **Product Demonstrations:** We intend to send members of our sale team to various kitchen and home appliance supply stores and retailers to conduct live demonstrations of our product, including assembly, installation, and effectiveness.

We anticipate that the costs associated with our initial marketing program will be approximately \$6,000. Additional Travel expenses associated with the development, production, and marketing of our Product are expected to be approximately \$4,000.

Management Expansion

We intend to expand our current management team to retain directors, officers and employees with experience relevant to our business focus. Our current officers are highly skilled in technical areas such as research and product development, and we are looking to add officers who have experience in marketing and business management to expand our company more effectively.

Sales Personnel

In the short term, we intend to use the services of our management to sell our products. As our product approaches the manufacturing stage, however, we plan to employ salespersons in the Philippines, and other Asian countries to promote and sell our Product. These sales representatives will be responsible for soliciting, selecting and securing accounts within a particular regional territory.

Expenses

We estimate the costs to implement our business strategy over the following twelve months to be:

- Travel and Related expenses, which will consist primarily of our executive officers and directors visiting home appliance merchants, retailers and wholesalers in their sales efforts. We estimate travel and related expenses for the next twelve months will be approximately \$4,000;
- Initial Marketing, which will consist of the marketing efforts discussed above, including direct marketing and attendance at trade shows. We estimate initial marketing expenses for the next twelve months will be approximately \$6,000;
- Research and Development costs consist of developing and testing our Product and determining the best combination of materials and suppliers for production. We estimate that research and development costs for the next twelve months will be approximately \$10,000.

We intend to obtain business capital through the use of private equity fundraising or shareholder loans. We anticipate that, in time, the primary source of revenues for our business model will be the sale of our Product.

Off Balance Sheet Transactions

We have had no off balance sheet transactions.

Significant Equipment

We do not intend to purchase any significant equipment for the next twelve months.

Results of Operations for the Three Months Ended December 31, 2009 and 2008 and Period from September 6, 2007 (Date of Inception) until December 31, 2009

We generated no revenue for the period from September 6, 2007 (Date of Inception) until December 31, 2009. We do not anticipate earning revenues until such time that we refine our Product and successfully market it to our target consumers. We are presently in the development stage of our business and we can provide no assurance that we will successfully implement our business plan.

Our Operating Expenses for the three months ended December 31, 2009 were \$2,000, as compared with \$2,000 for the three months ended December 31, 2008. Our Operating Expenses from September 6, 2007 (Date of Inception) to December 31, 2009 were \$61,500. Our Operating Expenses for all periods consisting entirely of Professional Fees.

We, therefore, recorded a net loss of \$2,000 for the three months ended December 31, 2009, as compared with \$2,000 for the three months ended December 31, 2008. We recorded a net loss of \$61,500 for the period from September 6, 2007 (Date of Inception) until December 31, 2009.

We anticipate our operating expenses will increase as we undertake our plan of operations. The increase will be attributable to the continued development of our Product and the professional fees associated with our becoming a reporting company under the Securities Exchange Act of 1934.

Results of Operations for the Years Ended September 30, 2009 and 2008, and for the period from Inception until September 30, 2009.

We have not earned any revenues since our inception on September 6, 2007 (Date of Inception) until September 30, 2009. We do not anticipate earning revenues until such time that we refine our Product and successfully market it to our target consumers. We are presently in the development stage of our business and we can provide no assurance that we will successfully implement our business plan.

We incurred operating expenses in the amount of \$11,000 for the year ended September 30, 2009, compared with \$44,500 for the year ended September 30, 2008. The entire amount for both periods was attributable to professional fees. We have incurred total operating expenses of \$59,500 from inception on September 6, 2007 through September 30, 2009. The entire amount was attributable to professional fees.

We incurred a net loss of \$11,000 for the year ended September 30, 2009, compared with \$44,500 for the year ended September 30, 2008. We incurred a total net loss of \$59,500 from inception on September 6, 2007 through September 30, 2009. Our losses for all periods are attributable to operating expenses together with a lack of any revenues.

Liquidity and Capital Resources

As of December 31, 2009, we had no current assets. We had \$18,500 in current liabilities as of December 31, 2009. Thus, we have a working capital deficit of \$18,500 as of December 31, 2009.

Operating activities used \$60,500 in cash for the period from September 6, 2007 (Date of Inception) until December 31, 2009. Our net loss of \$61,500 represented the causal factor of our negative operating cash flow. Financing Activities during the period from September 6, 2007 (Date of Inception) until December 31, 2009 generated \$60,500, represented by \$43,000 in cash from the sale of our common stock and \$17,500 from the proceeds of advances from an officer and director.

As of December 31, 2009, we have insufficient cash to operate our business at the current level for the next twelve months and insufficient cash to achieve our business goals. The success of our business plan beyond the next 12 months is contingent upon us obtaining additional financing. We intend to fund operations through debt and/or equity financing arrangements, which may be insufficient to fund our capital expenditures, working capital, or other cash requirements. We do not have any formal commitments or arrangements for the sales of stock or the advancement or loan of funds at this time. There can be no assurance that such additional financing will be available to us on acceptable terms, or at all.

As of September 30, 2009, we had no current assets. We had \$16,500 in current liabilities as of September 30, 2009. Thus, we have a working capital deficit of \$16,500 as of September 30, 2009.

Operating activities used \$58,500 in cash for the period from September 6, 2007 (Date of Inception) until September 30, 2009. Our net loss of \$59,500 represented the causal factor of our negative operating cash flow offset by accrued expenses of \$1,000. Financing Activities during the period from September 6, 2007 (Date of Inception) until September 30, 2009 generated \$58,500 in cash.

As of September 30, 2009, we have insufficient cash to operate our business at the current level for the next twelve months and insufficient cash to achieve our business goals. The success of our business plan beyond the next 12 months is contingent upon us obtaining additional financing. We intend to fund operations through debt and/or equity financing arrangements, which may be insufficient to fund our capital expenditures, working capital, or other cash requirements. We do not have any formal commitments or arrangements for the sales of stock or

the advancement or loan of funds at this time. There can be no assurance that such additional financing will be available to us on acceptable terms, or at all.

Going Concern

We have negative working capital and have not yet received revenues from sales of products or services. These factors create substantial doubt about our ability to continue as a going concern. The financial statements contained herein do not include any adjustment that might be necessary if we are unable to continue as a going concern.

Our ability to continue as a going concern is dependent on our generating cash from the sale of our common stock and/or obtaining debt financing and attaining future profitable operations. Management's plans include selling our equity securities and obtaining debt financing to fund out capital requirement and ongoing operations; however, there can be no assurance we will be successful in these efforts.

Certain Relationships and Related Transactions

None of the following parties has, since our date of incorporation, had any material interest, direct or indirect, in any transaction with us or in any presently proposed transaction that has or will materially affect us:

- Any of our directors or officers;
- Any person proposed as a nominee for election as a director;
- Any person who beneficially owns, directly or indirectly, shares carrying more than 10% of the voting rights attached to our outstanding shares of common stock;
- Any of our promoters;
- Any relative or spouse of any of the foregoing persons who has the same house address as such person.

Market for Common Equity and Related Stockholder Matters

Market Information

Our common stock is currently quoted on the OTC Bulletin Board ("OTCBB"), which is sponsored by FINRA. The OTCBB is a network of security dealers who buy and sell stock. The dealers are connected by a computer network that provides information on current "bids" and "asks", as well as volume information. Our shares are quoted on the OTCBB under the symbol "WDST."

The following table sets forth the range of high and low bid quotations for our common stock for each of the periods indicated as reported by the OTCBB. These quotations reflect inter-dealer prices, without retail mark-up, mark-down or commission and may not necessarily represent actual transactions.

Fiscal Year Ending September 30, 2009

Quarter Ended	High \$	Low \$
September 30, 2009	N/A	N/A
June 30, 2009	N/A	N/A
March 31, 2009	N/A	N/A
December 31, 2008	N/A	N/A

Fiscal Year Ending September 30, 2008

Quarter Ended	High \$	Low \$
September 30, 2008	N/A	N/A
June 30, 2008	N/A	N/A
March 31, 2008	N/A	N/A
December 31, 2007	N/A	N/A

The Securities Exchange Commission has adopted rules that regulate broker-dealer practices in connection with transactions in penny stocks. Penny stocks are generally equity securities with a price of less than \$5.00, other than securities registered on certain national securities exchanges or quoted on the NASDAQ system, provided that current price and volume information with respect

to transactions in such securities is provided by the exchange or system. The penny stock rules require a broker-dealer, prior to a transaction in a penny stock, to deliver a standardized risk disclosure document prepared by the Commission, that: (a) contains a description of the nature and level of risk in the market for penny stocks in both public offerings and secondary trading;(b) contains a description of the broker's or dealer's duties to the customer and of the rights and remedies available to the customer with respect to a violation to such duties or other requirements of Securities' laws; (c) contains a brief, clear, narrative description of a dealer market, including bid and ask prices for penny stocks and the significance of the spread between the bid and ask price;(d) contains a toll-free telephone number for inquiries on disciplinary actions;(e) defines significant terms in the disclosure document or in the conduct of trading in penny stocks; and;(f) contains such other information and is in such form, including language, type, size and format, as the Commission shall require by rule or regulation.

The broker-dealer also must provide, prior to effecting any transaction in a penny stock, the customer with; (a) bid and offer quotations for the penny stock;(b) the compensation of the broker-dealer and its salesperson in the transaction;(c) the number of shares to which such bid and ask prices apply, or other comparable information relating to the depth and liquidity of the market for such stock; and (d) a monthly account statements showing the market value of each penny stock held in the customer's account.

In addition, the penny stock rules require that prior to a transaction in a penny stock not otherwise exempt from those rules; the broker-dealer must make a special written determination that the penny stock is a suitable investment for the purchaser and receive the purchaser's written acknowledgment of the receipt of a risk disclosure statement, a written agreement to transactions involving penny stocks, and a signed and dated copy of a written suitability statement.

These disclosure requirements may have the effect of reducing the trading activity in the secondary market for our stock if it becomes subject to these penny stock rules. Therefore, because our common stock is subject to the penny stock rules, stockholders may have difficulty selling those securities.

Holders of Our Common Stock

Currently, we have forty (40) holders of record of our common stock.

Stock Option Grants

To date, we have not granted any stock options.

Registration Rights

We have not granted registration rights to the selling shareholders or to any other persons.

We are paying the expenses of the offering because we seek to: (i) become a reporting company with the Commission under the Securities Exchange Act of 1934; and (ii) enable our common stock to be traded on the OTCBB. We believe that the registration of the resale of shares on behalf of existing shareholders may facilitate the development of a public market in our common stock if our common stock is approved for trading on a recognized market for the trading of securities in the United States.

We consider that the development of a public market for our common stock will make an investment in our common stock more attractive to future investors. We believe that obtaining reporting company status under the 1934 Act and trading on the OTCBB should increase our ability to raise these additional funds from investors.

Dividends

There are no restrictions in our articles of incorporation or bylaws that prevent us from declaring dividends. The Nevada Revised Statutes, however, do prohibit us from declaring dividends where after giving effect to the distribution of the dividend:

1. we would not be able to pay our debts as they become due in the usual course of business, or;
2. our total assets would be less than the sum of our total liabilities plus the amount that would be needed to satisfy the rights of shareholders who have preferential rights superior to those receiving the distribution.

We have not declared any dividends and we do not plan to declare any dividends in the foreseeable future.

Executive Compensation

Summary Compensation Table

The table below summarizes all compensation awarded to, earned by, or paid to both to our officers and to our directors for all services rendered in all capacities to us for our fiscal years ended September 30, 2009, 2008 and 2007.

SUMMARY COMPENSATION TABLE									
Name and principal position	Year	Salary (\$)	Bonus (\$)	Stock Awards (\$)	Option Awards (\$)	Non-Equity Incentive Plan Compensation (\$)	Nonqualified Deferred Compensation Earnings (\$)	All Other Compensation (\$)	Total (\$)
Siew Mee Fam									
President, Chief Executive Officer, Principal Executive Officer, Chief Financial Officer, Principal Accounting Officer and Director	2009	0	0	0	0	0	0	0	0
	2008	0	0	0	0	0	0	0	0
	2007	0	0	0	0	0	0	0	0

Narrative Disclosure to the Summary Compensation Table

We have not entered into any employment agreement or consulting agreement with our executive officers. There are no arrangements or plans in which we provide pension, retirement or similar benefits for executive officers.

Although we do not currently compensate our officers, we reserve the right to provide compensation at some time in the future. Our decision to compensate officers depends on the availability of our cash resources with respect to the need for cash to further our business purposes.

Outstanding Equity Awards at Fiscal Year-End

The table below summarizes all unexercised options, stock that has not vested, and equity incentive plan awards for each named executive officer as of September 30, 2009.

OUTSTANDING EQUITY AWARDS AT FISCAL YEAR-END										
OPTION AWARDS										
STOCK AWARDS										
Name	Number of Securities Underlying Unexercised Options (#)	Number of Securities Underlying Unexercised Options (#)	Equity Incentive Awards: Number of Securities Underlying Unexercised Options (#)	Option Exercise Price (\$)	Option Expiration Date	Number of Shares or Units of Stock That Have Not Vested (#)	Market Value of Shares or Units of Stock That Have Not Vested (\$)	Equity Incentive Plan Awards: Number of Shares, Units or Rights That Have Not Vested (#)	Equity Incentive Plan Awards: Market or Value of Unearned Shares, Units or Rights That Have Not Vested (\$)	Equity Incentive Plan Awards: Market or Value of Unearned Shares, Units or Rights That Have Not Vested (\$)
Siew Mee Fam	-	-	-	-	-	-	-	-	-	-

Stock Option Grants

We have not granted any stock options to the executive officers or directors since our inception.

Director Compensation

The table below summarizes all compensation awarded to, earned by, or paid to our directors for all services rendered in all capacities to us for the period from inception through September 30, 2009.

DIRECTOR COMPENSATION							
Name	Fees Earned or Paid in Cash (\$)	Stock Awards (\$)	Option Awards (\$)	Non-Equity Incentive Plan Compensation (\$)	Non-Qualified Deferred Compensation Earnings (\$)	All Other Compensation (\$)	Total (\$)
Sze Yein Wong	0	0	0	0	0	0	0

Narrative Disclosure to the Director Compensation Table

We do not pay any compensation to our directors at this time. However, we reserve the right to compensate our directors in the future with cash, stock, options, or some combination of the above.

We have not reimbursed our directors for expenses incurred in connection with attending board meetings nor have we paid any directors fees or other cash compensation for services rendered as a director in the year ended September 30, 2009.

Stock Option Plans

We did not have a stock option plan as of September 30, 2009.

Financial Statements

Index to Financial Statements Required by Article 8 of Regulation S-X:

- F-1 Balance Sheets as of December 31, 2009 (unaudited) and September 30, 2009 (audited);
- F-2 Statements of Operations for the three months ended December 31, 2009 and 2008, and period from September 6, 2007 (Inception) to December 31, 2009 (unaudited);
- F-3 Statement of Stockholders' Deficit for period from September 6, 2007 (Inception) to December 31, 2009 (unaudited);
- F-4 Statements of Cash Flows for the three months ended December 31, 2009 and 2008, and period from September 6, 2007 (Inception) to December 31, 2009 (unaudited);
- F-5 Notes to Financial Statements;

Audited Financial Statements:

- F-8 Report of Independent Registered Public Accounting Firm
- F-9 Consolidated Balance Sheets as of September 30, 2009 and 2008;
- F-10 Statements of Operations for the years ended September 30, 2009, and September 30, 2008, and the period from inception to September 30, 2009;
- F-11 Statement of Stockholders' Equity for period from inception to September 30, 2009;
- F-12 Statements of Cash Flows for the years ended September 30, 2009, and September 30, 2008, and the period from inception to September 30, 2009;
- F-13 Notes to Financial Statements

WINDSTAR, INC.
(A DEVELOPMENT STAGE COMPANY)
BALANCE SHEETS
As of December 31, 2009 and September 30, 2009

	December 31, 2009 (unaudited)	September 30, 2009 (audited)
ASSETS		
Current Assets		
Cash and equivalents	\$ -0-	\$ -0-
Prepaid expenses	-0-	-0-
TOTAL ASSETS	\$ -0-	\$ -0-
LIABILITIES AND STOCKHOLDERS' DEFICIT		
Liabilities		
Current Liabilities		
Accrued expenses	\$ 1,000	\$ 1,000
Due to officer	17,500	15,500
Total liabilities	18,500	16,500
Stockholders' Deficit		
Common Stock, \$.001 par value, 100,000,000 shares authorized, 2,150,000 shares issued and outstanding		
Additional paid-in capital	2,150	2,150
40,850	40,850	40,850
Deficit accumulated during the development stage	(61,500)	(59,500)
Total stockholders' deficit	(18,500)	(16,500)
TOTAL LIABILITIES AND STOCKHOLDERS' DEFICIT	\$ -0-	\$ -0-

See accompanying notes to financial statements.

WINDSTAR, INC.
(A DEVELOPMENT STAGE COMPANY)
STATEMENTS OF OPERATIONS (unaudited)
Three Months Ended December 31, 2009 and 2008
Period from September 6, 2007 (Inception) to December 31, 2009

	Three Months Ended December 31, 2009	Three Months Ended December 31, 2008	Period from September 6, 2007 (Inception) to December 31, 2009
Revenues	\$ -0-	\$ -0-	\$ -0-
Expenses :			
Professional fees	<u>2,000</u>	<u>2,000</u>	<u>61,500</u>
Net Loss	<u>\$ (2,000)</u>	<u>\$ (2,000)</u>	<u>\$ (61,500)</u>
Net loss per share:			
Basic and diluted	<u>\$ (0.00)</u>	<u>\$ (0.02)</u>	<u>\$ (0.02)</u>
Weighted average shares outstanding:			
Basic and diluted	<u>2,150,000</u>	<u>2,150,000</u>	<u>2,150,000</u>

See accompanying notes to financial statements.

WINDSTAR, INC.
(A DEVELOPMENT STAGE COMPANY)
STATEMENT OF STOCKHOLDERS' DEFICIT (unaudited)
Period from September 6, 2007 (Inception) to December 31, 2009

	Common stock		Additional paid-in capital	Deficit accumulated during the development stage	Total
	Shares	Amount			
Issuance of common stock for cash @\$.001	2,150,000	\$ 2,150	\$ 40,850	\$ -	\$ 43,000
Net loss for the period ended September 30, 2007	-	-	-	(4,000)	(4,000)
Balance, September 30, 2007	2,150,000	2,150	40,850	(4,000)	39,000
Net loss for the year ended September 30, 2008	-	-	-	(44,500)	(44,500)
Balance, September 30, 2008	2,150,000	2,150	40,850	(48,500)	(5,500)
Net loss for the year ended September 30, 2009	-	-	-	(11,000)	(11,000)
Balance, September 30, 2009	2,150,000	2,150	40,850	(59,500)	(16,500)
Net loss for the period ended December 31, 2009	-	-	-	(2,000)	(2,000)
Balance, December 31, 2009	2,150,000	\$ 2,150	\$ 40,850	\$ (61,500)	\$ (18,500)

See accompanying notes to financial statements.

WINDSTAR, INC.
(A DEVELOPMENT STAGE COMPANY)
STATEMENTS OF CASH FLOWS (unaudited)
Three Months Ended December 31, 2009 and 2008
Period from September 6, 2007 (Inception) to December 31, 2009

	Three Months Ended December 31, 2009	Three Months Ended December 31, 2008	Period From September 6, 2007 (Inception) to December 31, 2009
CASH FLOWS FROM OPERATING ACTIVITIES			
Net loss	\$ (2,000)	\$ (2,000)	\$ (61,500)
Change in non-cash working capital items			
Prepaid expenses	-0-	-0-	-0-
Accrued expenses	-0-	-0-	1,000
CASH FLOWS USED BY OPERATING ACTIVITIES	(2,000)	(2,000)	(60,500)
CASH FLOWS FROM FINANCING ACTIVITIES			
Proceeds from sales of common stock	-0-	-0-	43,000
Advances from officer	2,000	-0-	17,500
CASH FLOWS PROVIDED BY FINANCING ACTIVITIES	2,000	-0-	60,500
NET DECREASE IN CASH	-0-	-0-	-0-
Cash, beginning of period	-0-	-0-	-0-
Cash, end of period	<u>\$ -0-</u>	<u>\$ -0-</u>	<u>\$ -0-</u>
SUPPLEMENTAL CASH FLOW INFORMATION			
Interest paid	<u>\$ -0-</u>	<u>\$ -0-</u>	<u>\$ -0-</u>
Income taxes paid	<u>\$ -0-</u>	<u>\$ -0-</u>	<u>\$ -0-</u>

See accompanying notes to financial statements.

WINDSTAR, INC.
(A DEVELOPMENT STAGE COMPANY)
NOTES TO THE FINANCIAL STATEMENTS
December 31, 2009

NOTE 1 – SUMMARY OF ACCOUNTING POLICIES

Nature of Business

Windstar, Inc. (“Windstar”) is a development stage company and was incorporated in Nevada on September 6, 2007. The Company is developing a cooking smoke purifier. Windstar operates out of office space owned by a director and stockholder of the Company. The facilities are provided at no charge. There can be no assurances that the facilities will continue to be provided at no charge in the future.

Development Stage Company

The accompanying financial statements have been prepared in accordance with accounting principles related to development-stage companies. A development-stage company is one in which planned principal operations have not commenced or if its operations have commenced, there has been no significant revenues there from.

Basis of Presentation

The accompanying unaudited interim financial statements have been prepared in accordance with accounting principles generally accepted in the United States of America and the rules of the Securities and Exchange Commission (“SEC”), and should be read in conjunction with the audited financial statements and notes thereto contained in the Company’s annual report filed with the SEC on Form 10-K. In the opinion of management, all adjustments necessary in order for the financial statements to be not misleading have been reflected herein. The results of operations for interim periods are not necessarily indicative of the results to be expected for the full year. Notes to the financial statements which would substantially duplicate the disclosure contained in the audited financial statements as of and for the periods ended September 30, 2009 as reported in Form 10-K, have been omitted.

Cash and Cash Equivalents

Windstar considers all highly liquid investments with maturities of three months or less to be cash equivalents. At December 31, 2009 and September 30, 2009, the Company had \$0 of cash.

Fair Value of Financial Instruments

Windstar’s financial instruments consist of cash and cash equivalents, accrued expenses, and an amount due to officer. The carrying amount of these financial instruments approximates fair value due either to length of maturity or interest rates that approximate prevailing market rates unless otherwise disclosed in these financial statements.

WINDSTAR, INC.
(A DEVELOPMENT STAGE COMPANY)
NOTES TO THE FINANCIAL STATEMENTS
December 31, 2009

NOTE 1 – SUMMARY OF ACCOUNTING POLICIES (continued)

Income Taxes

Income taxes are computed using the asset and liability method. Under the asset and liability method, deferred income tax assets and liabilities are determined based on the differences between the financial reporting and tax bases of assets and liabilities and are measured using the currently enacted tax rates and laws. A valuation allowance is provided for the amount of deferred tax assets that, based on available evidence, are not expected to be realized.

Use of Estimates

The preparation of financial statements in conformity with generally accepted accounting principles requires management to make estimates and assumptions that affect the reported amounts of assets and liabilities and disclosure of contingent assets and liabilities at the date the financial statements and the reported amount of revenues and expenses during the reporting period. Actual results could differ from those estimates.

Basic loss per share

Basic loss per share has been calculated based on the weighted average number of shares of common stock outstanding during the period.

Recent Accounting Pronouncements

Windstar does not expect the adoption of recently issued accounting pronouncements to have a significant impact on the Company's results of operations, financial position or cash flow.

NOTE 2 – ACCRUED EXPENSES

Accrued expenses at December 31, 2009 and 2008 consisted of an amounts owed for professional fees for services rendered during the respective periods.

NOTE 3 – DUE TO OFFICER

The amount due to officer of \$17,500 at December 31, 2009 consisted of amounts owed to an officer of the Company for amounts advanced to pay for professional services provided by the Company's outside independent auditors for services rendered for periods ending on and prior to December 31, 2009. The amount is unsecured, due upon demand, and non-interest bearing.

WINDSTAR, INC.
(A DEVELOPMENT STAGE COMPANY)
NOTES TO THE FINANCIAL STATEMENTS
December 31, 2009

NOTE 4 – INCOME TAXES

For the periods ended December 31, 2009, Windstar has incurred net losses and, therefore, has no tax liability. The net deferred tax asset generated by the loss carry-forward has been fully reserved. The cumulative net operating loss carry-forward is approximately \$61,500 at December 31, 2009, and will expire beginning in the year 2027.

The cumulative tax effect at the expected rate of 34% of significant items comprising our net deferred tax amount is as follows:

	<u>2009</u>
Deferred tax asset attributable	
to:	
Net operating loss carryover	\$ 20,910
Valuation allowance	(20,910)
Net deferred tax asset	<u>\$ -</u>

NOTE 5 – LIQUIDITY AND GOING CONCERN

Windstar has negative working capital, has incurred losses since inception, and has not yet received revenues from sales of products or services. These factors create substantial doubt about the Company's ability to continue as a going concern. The financial statements do not include any adjustment that might be necessary if the Company is unable to continue as a going concern.

The ability of Windstar to continue as a going concern is dependent on the Company generating cash from the sale of its common stock and/or obtaining debt financing and attaining future profitable operations. Management's plans include selling its equity securities and obtaining debt financing to fund its capital requirement and ongoing operations; however, there can be no assurance the Company will be successful in these efforts.

NOTE 6 - SUBSEQUENT EVENTS

Management has evaluated subsequent events through the date on which the financial statements were submitted to the Securities and Exchange Commission and has determined it does not have any material subsequent events to disclose.

REPORT OF INDEPENDENT REGISTERED PUBLIC ACCOUNTING FIRM

To the Board of Directors of
Windstar, Inc.
Reno, Nevada

We have audited the accompanying balance sheet of Windstar, Inc. as of September 30, 2009 and 2008, and the related statements of operations, stockholders' deficit, and cash flows for the years then ended and for the period from September 6, 2007 (inception) to September 30, 2009. These financial statements are the responsibility of the Company's management. Our responsibility is to express an opinion on these financial statements based on our audit.

We conducted our audits in accordance with the standards of the Public Company Accounting Oversight Board (United States). Those standards require that we plan and perform the audits to obtain reasonable assurance about whether the financial statements are free of material misstatement. The Company has determined that it is not required to have, nor were we engaged to perform, an audit of its internal control over financial reporting. Our audits included consideration of internal control over financial reporting as a basis for designing audit procedures that are appropriate in the circumstances, but not for the purpose of expressing an opinion on the effectiveness of the Company's internal control over financial reporting. Accordingly, we express no such opinion. An audit includes examining on a test basis, evidence supporting the amounts and disclosures in the financial statements. An audit also includes assessing the accounting principles used and significant estimates made by management, as well as evaluating the overall financial statement presentation. We believe that our audits provide a reasonable basis for our opinion.

In our opinion, the financial statements referred to above present fairly, in all material respects, the financial position of Windstar, Inc. as of September 30, 2009 and 2008, and the results of its operations and cash flows for the years then ended and for the period from September 7, 2006 (inception) to September 30, 2009, in conformity with accounting principles generally accepted in the United States of America.

The accompanying consolidated financial statements have been prepared assuming that the Company will continue as a going concern. As discussed in Note 5 to the financial statements, the Company has negative working capital, has not yet received revenue from sales of products or services, and has incurred losses since inception. These factors raise substantial doubt about the Company's ability to continue as a going concern. Management's plans with regard to these matters are described in Note 5. The accompanying financial statements do not include any adjustments that might result from the outcome of this uncertainty.

/s/ Maddox Ungar Silberstein, PLLC

Maddox Ungar Silberstein, PLLC
Bingham Farms, Michigan
January 6, 2010

WINDSTAR, INC.
(A DEVELOPMENT STAGE COMPANY)
BALANCE SHEETS
As of September 30, 2009 and September 30, 2008

	<u>September 30, 2009</u>	<u>September 30, 2008</u>
ASSETS		
Current Assets		
Cash and equivalents	\$ -0-	\$ -0-
Prepaid expenses	<u>-0-</u>	<u>-0-</u>
TOTAL ASSETS	<u><u>\$ -0-</u></u>	<u><u>\$ -0-</u></u>
LIABILITIES AND STOCKHOLDERS' DEFICIT		
Liabilities		
Current Liabilities		
Accrued expenses	\$ 1,000	\$ 5,500
Due to officer	<u>15,500</u>	<u>-0-</u>
Total liabilities	<u>16,500</u>	<u>5,500</u>
Stockholders' Deficit		
Common Stock, \$.001 par value, 100,000,000 shares authorized, 2,150,000 shares issued and outstanding	2,150	2,150
Additional paid-in capital	40,850	40,850
Deficit accumulated during the development stage	<u>(59,500)</u>	<u>(48,500)</u>
Total stockholders' deficit	<u>(16,500)</u>	<u>(5,500)</u>
TOTAL LIABILITIES AND STOCKHOLDERS' DEFICIT	<u><u>\$ -0-</u></u>	<u><u>\$ -0-</u></u>

See accompanying notes to financial statements.

WINDSTAR, INC.
(A DEVELOPMENT STAGE COMPANY)
STATEMENTS OF OPERATIONS
Years Ended September 30, 2009 and 2008
Period from September 6, 2007 (Inception) to September 30, 2009

	Year Ended September 30, 2009	Year Ended September 30, 2008	Period from September 6, 2007 (Inception) to September 30, 2009
Revenues	\$ -0-	\$ -0-	\$ -0-
Expenses :			
Professional fees	<u>11,000</u>	<u>44,500</u>	<u>59,500</u>
Net Loss	<u>\$ (11,000)</u>	<u>\$ (44,500)</u>	<u>\$ (59,500)</u>
Net loss per share:			
Basic and diluted	<u>\$ (0.00)</u>	<u>\$ (0.02)</u>	<u>\$ (0.02)</u>
Weighted average shares outstanding:			
Basic and diluted	<u>2,150,000</u>	<u>2,150,000</u>	<u>2,150,000</u>

See accompanying notes to financial statements.

WINDSTAR, INC.
(A DEVELOPMENT STAGE COMPANY)
STATEMENT OF STOCKHOLDERS' DEFICIT
Period from September 6, 2007 (Inception) to September 30, 2009

	Common stock		Additional paid-in capital	Deficit accumulated during the development stage	Total
	Shares	Amount			
Issuance of common stock for cash @\$.001	2,150,000	\$ 2,150	\$ 40,850	\$ -	\$ 43,000
Net loss for the period ended September 30, 2007	-	-	-	(4,000)	(4,000)
Balance, September 30, 2007	2,150,000	2,150	40,850	(4,000)	39,000
Net loss for the year ended September 30, 2008	-	-	-	(44,500)	(44,500)
Balance, September 30, 2008	2,150,000	2,150	40,850	(48,500)	(5,500)
Net loss for the year ended September 30, 2009	-	-	-	(11,000)	(11,000)
Balance, September 30, 2009	2,150,000	\$ 2,150	\$ 40,850	\$ (59,500)	\$ (16,500)

See accompanying notes to financial statements.

WINDSTAR, INC.
(A DEVELOPMENT STAGE COMPANY)
STATEMENTS OF CASH FLOWS
Years Ended September 30, 2009 and 2008
Period from September 6, 2007 (Inception) to September 30, 2009

	Year	Year	Period From September 6, 2007 (Inception) to September 30, 2009
	Ended September 30, 2009	Ended September 30, 2008	September 30, 2009
CASH FLOWS FROM OPERATING ACTIVITIES			
Net loss	\$ (11,000)	\$ (44,500)	\$ (59,500)
Change in non-cash working capital items			
Prepaid expenses	-0-	-0-	-0-
Accrued expenses	(4,500)	5,500	1,000
		0-	
CASH FLOWS USED BY OPERATING ACTIVITIES	(15,500)	4,265	(58,500)
CASH FLOWS FROM FINANCING ACTIVITIES			
Proceeds from sales of common stock	-0-	-0-	43,000
Advances from officer	15,500	-0-	15,500
CASH FLOWS PROVIDED BY FINANCING ACTIVITIES	15,500	-0-	58,500
NET DECREASE IN CASH	-0-	-0-	-0-
Cash, beginning of period	-0-	-0-	-0-
Cash, end of period	<u>\$ -0-</u>	<u>\$ -0-</u>	<u>\$ -0-</u>
SUPPLEMENTAL CASH FLOW INFORMATION			
Interest paid	<u>\$ -0-</u>	<u>\$ -0-</u>	<u>\$ -0-</u>
Income taxes paid	<u>\$ -0-</u>	<u>\$ -0-</u>	<u>\$ -0-</u>

See accompanying notes to financial statements.

WINDSTAR, INC.
(A DEVELOPMENT STAGE COMPANY)
NOTES TO THE FINANCIAL STATEMENTS
September 30, 2009

NOTE 1 – SUMMARY OF ACCOUNTING POLICIES

Nature of Business

Windstar, Inc. (“Windstar”) is a development stage company and was incorporated in Nevada on September 6, 2007. The Company is developing a cooking smoke purifier. Windstar operates out of office space owned by a director and stockholder of the Company. The facilities are provided at no charge. There can be no assurances that the facilities will continue to be provided at no charge in the future.

Development Stage Company

The accompanying financial statements have been prepared in accordance with accounting principles related to development-stage companies. A development-stage company is one in which planned principal operations have not commenced or if its operations have commenced, there has been no significant revenues there from.

Cash and Cash Equivalents

Windstar considers all highly liquid investments with maturities of three months or less to be cash equivalents. At September 30, 2009 and September 30, 2008, the Company had \$0 of cash.

Fair Value of Financial Instruments

Windstar’s financial instruments consist of cash and cash equivalents and accrued expenses. The carrying amount of these financial instruments approximates fair value due either to length of maturity or interest rates that approximate prevailing market rates unless otherwise disclosed in these financial statements.

Income Taxes

Income taxes are computed using the asset and liability method. Under the asset and liability method, deferred income tax assets and liabilities are determined based on the differences between the financial reporting and tax bases of assets and liabilities and are measured using the currently enacted tax rates and laws. A valuation allowance is provided for the amount of deferred tax assets that, based on available evidence, are not expected to be realized.

Use of Estimates

The preparation of financial statements in conformity with generally accepted accounting principles requires management to make estimates and assumptions that affect the reported amounts of assets and liabilities and disclosure of contingent assets and liabilities at the date the financial statements and the reported amount of revenues and expenses during the reporting period. Actual results could differ from those estimates.

WINDSTAR, INC.
(A DEVELOPMENT STAGE COMPANY)
NOTES TO THE FINANCIAL STATEMENTS
September 30, 2009

NOTE 1 – SUMMARY OF ACCOUNTING POLICIES (continued)

Basic loss per share

Basic loss per share has been calculated based on the weighted average number of shares of common stock outstanding during the period.

Recent Accounting Pronouncements

Windstar does not expect the adoption of recently issued accounting pronouncements to have a significant impact on the Company’s results of operations, financial position or cash flow.

NOTE 2 – ACCRUED EXPENSES

Accrued expenses at September 30, 2009 and 2008 consisted of an amounts owed for professional fees for services rendered during the respective periods.

NOTE 3 – DUE TO OFFICER

The amount due to officer of \$15,500 at September 30, 2009 consisted of amounts owed to an officer of the Company for amounts advanced to pay for professional services provided by the Company’s outside independent auditors for services rendered for periods ending on and prior to September 30, 2009. The amount is unsecured, due upon demand, and non-interest bearing.

NOTE 4 – INCOME TAXES

For the periods ended September 30, 2009, Windstar has incurred net losses and, therefore, has no tax liability. The net deferred tax asset generated by the loss carry-forward has been fully reserved. The cumulative net operating loss carry-forward is approximately \$59,500 at September 30, 2009, and will expire beginning in the year 2027.

The cumulative tax effect at the expected rate of 34% of significant items comprising our net deferred tax amount is as follows:

	2009
Deferred tax asset attributable to:	
Net operating loss carryover	\$ 20,230
Valuation allowance	(20,230)
Net deferred tax asset	\$ -

WINDSTAR, INC.
(A DEVELOPMENT STAGE COMPANY)
NOTES TO THE FINANCIAL STATEMENTS
September 30, 2009

NOTE 5 – LIQUIDITY AND GOING CONCERN

Windstar has negative working capital, has incurred losses since inception, and has not yet received revenues from sales of products or services. These factors create substantial doubt about the Company's ability to continue as a going concern. The financial statements do not include any adjustment that might be necessary if the Company is unable to continue as a going concern.

The ability of Windstar to continue as a going concern is dependent on the Company generating cash from the sale of its common stock and/or obtaining debt financing and attaining future profitable operations. Management's plans include selling its equity securities and obtaining debt financing to fund its capital requirement and ongoing operations; however, there can be no assurance the Company will be successful in these efforts.

NOTE 6 - SUBSEQUENT EVENTS

Management has evaluated subsequent events through the date on which the financial statements were submitted to the Securities and Exchange Commission and has determined it does not have any material subsequent events to disclose.

Changes In and Disagreements with Accountants

We have had no changes in or disagreements with our accountants.

Available Information

We have filed a registration statement on form S-1 under the Securities Act of 1933 with the Securities and Exchange Commission with respect to the shares of our common stock offered through this prospectus. This prospectus is filed as a part of that registration statement, but does not contain all of the information contained in the registration statement and exhibits. Statements made in the registration statement are summaries of the material terms of the referenced contracts, agreements or documents of the company. We refer you to our registration statement and each exhibit attached to it for a more detailed description of matters involving the company, and the statements we have made in this prospectus are qualified in their entirety by reference to these additional materials. You may inspect the registration statement, exhibits and schedules filed with the Securities and Exchange Commission at the Commission's principal office in Washington, D.C. Copies of all or any part of the registration statement may be obtained from the Public Reference Section of the Securities and Exchange Commission, 100 F. Street, N.E. Washington, D.C. 20549. Please Call the Commission at 1-800-SEC-0330 for further information on the operation of the public reference rooms. The Securities and Exchange Commission also maintains a Web Site at <http://www.sec.gov> that contains reports, proxy Statements and information regarding registrants that files electronically with the Commission. Our registration statement and the referenced exhibits can also be found on this site.

If we are not required to provide an annual report to our security holders, we intend to still voluntarily do so when otherwise due, and will attach audited financial statements with such report.

Until _____, all dealers that effect transactions in these securities whether or not participating in this offering may be required to deliver a prospectus. This is in addition to the dealers' obligation to deliver a prospectus when acting as underwriters and with respect to their unsold allotments or subscriptions.

Part II

Information Not Required In the Prospectus

Item 13. Other Expenses of Issuance and Distribution

The estimated costs of this offering are as follows:

Securities and Exchange Commission registration fee	\$ 1
Federal Taxes	\$ 0
State Taxes and Fees	\$ 0
Listing Fees	\$ 0
Printing and Engraving Fees	\$ 1,000
Transfer Agent Fees	\$ 1,000
Accounting fees and expenses	\$ 15,000
Legal fees and expenses	<u>\$ 10,000</u>
Total	<u>\$ 27,001</u>

All amounts are estimates.

We are paying all expenses of the offering listed above. No portion of these expenses will be borne by the selling shareholders. The selling shareholders, however, will pay any other expenses incurred in selling their common stock, including any brokerage commissions or costs of sale.

Item 14. Indemnification of Directors and Officers

Our officers and directors are indemnified as provided by the Nevada Revised Statutes and our bylaws.

Under the governing Nevada statutes, director immunity from liability to a company or its shareholders for monetary liabilities applies automatically unless it is specifically limited by a company's articles of incorporation. Our articles of incorporation do not contain any limiting language regarding director immunity from liability. Excepted from this immunity are:

1. a willful failure to deal fairly with the company or its shareholders in connection with a matter in which the director has a material conflict of interest;
2. a violation of criminal law (unless the director had reasonable cause to believe that his or her conduct was lawful or no reasonable cause to believe that his or her conduct was unlawful);
3. a transaction from which the director derived an improper personal profit; and
4. willful misconduct.

Our bylaws provide that we will indemnify our directors and officers to the fullest extent not prohibited by Nevada law; provided, however, that we may modify the extent of such indemnification by individual contracts with our directors and officers; and, provided, further, that we shall not be required to indemnify any director or officer in connection with any proceeding (or part thereof) initiated by such person unless:

1. such indemnification is expressly required to be made by law;
2. the proceeding was authorized by our Board of Directors;
3. such indemnification is provided by us, in our sole discretion, pursuant to the powers vested us under Nevada law; or;
4. such indemnification is required to be made pursuant to the bylaws.

Our bylaws provide that we will advance to any person who was or is a party or is threatened to be made a party to any threatened, pending or completed action, suit or proceeding, whether civil, criminal, administrative or investigative, by reason of the fact that he is or was a director or officer, of the company, or is or was serving at the request of the company as a director or executive officer

of another company, partnership, joint venture, trust or other enterprise, prior to the final disposition of the proceeding, promptly following request therefore, all expenses incurred by any director or officer in connection with such proceeding upon receipt of an undertaking by or on behalf of such person to repay said amounts if it should be determined ultimately that such person is not entitled to be indemnified under our bylaws or otherwise.

Our bylaws provide that no advance shall be made by us to an officer of the company, except by reason of the fact that such officer is or was a director of the company in which event this paragraph shall not apply, in any action, suit or proceeding, whether civil, criminal, administrative or investigative, if a determination is reasonably and promptly made: (a) by the board of directors by a majority vote of a quorum consisting of directors who were not parties to the proceeding, or (b) if such quorum is not obtainable, or, even if obtainable, a quorum of disinterested directors so directs, by independent legal counsel in a written opinion, that the facts known to the decision-making party at the time such determination is made demonstrate clearly and convincingly that such person acted in bad faith or in a manner that such person did not believe to be in or not opposed to the best interests of the company.

Item 15. Recent Sales of Unregistered Securities

We issued 600,000 shares of common stock on September 6, 2007, to Siew Mee Fam, our officer and director. These shares were issued pursuant to Regulation S of the Securities Act of 1933 (the "Securities Act") at a price of \$0.02 per share, for total proceeds of \$12,000. The 600,000 shares of common stock are restricted shares as defined in the Securities Act.

We issued 600,000 shares of common stock on September 6, 2007, to Sze Yein Wong, our director. These shares were issued pursuant to Regulation S of the Securities Act of 1933 (the "Securities Act") at a price of \$0.02 per share, for total proceeds of \$12,000. The 600,000 shares of common stock are restricted shares as defined in the Securities Act.

We completed a private placement of 925,000 shares of our common stock pursuant to Regulation S of the 1933 Act on September 6, 2007. All shares were issued at a price of \$0.02 per share. We received proceeds of \$18,500 from the offering. Each purchaser represented to us that the purchaser was a Non-US Person as defined in Regulation S. We did not engage in a distribution of this offering in the United States. Each purchaser represented their intention to acquire the securities for investment only and not with a view toward distribution. All purchasers were given adequate access to sufficient information about us to make an informed investment decision. None of the securities were sold through an underwriter and accordingly, there were no underwriting discounts or commissions involved. The selling stockholders named in this prospectus include all of the purchasers who purchased shares pursuant to this Regulation S offering.

Item 16. Exhibits

<u>Exhibit Number</u>	<u>Description</u>
3.1	Articles of Incorporation, as amended(1)
3.2	By-Laws(1)
5.1	Opinion of David S. Jennings, Esq., with consent to use(1)
23.1	Consent of Silberstein Ungar, PLLC (formerly known as Maddox Ungar Silberstein, PLLC)
24.1	Power of Attorney (see attached signature page)

(1) Incorporated by reference to same exhibit filed with the Company's Form SB-2 Registration Statement on October 22, 2007.

Item 17. Undertakings

The undersigned registrant hereby undertakes:

(1) To file, during any period in which offers or sales are being made, a post-effective amendment to this registration statement: (i) to include any prospectus required by Section 10(a)(3) of the Securities Act of 1933; (ii) to reflect in the prospectus any facts or events arising after the effective date of the registration statement (or the most recent post-effective amendment thereof) which, individually or in the aggregate, represent a fundamental change in the information set forth in the registration statement. Notwithstanding the foregoing, any increase or decrease in volume of securities offered (if the total dollar value of securities offered would not exceed that which was registered) and any deviation from the low or high end of the estimated maximum offering range may be reflected in the form of prospectus filed with the Commission pursuant to Rule 424(b) if, in the aggregate, the changes in volume and price represent no more than 20 percent change in the maximum aggregate offering price set forth in the "Calculation of Registration Fee" table in the effective registration statement; and (iii) to include any material information with respect to the plan of distribution not previously disclosed in the registration statement or any material change to such information in the registration statement.

(2) That, for the purpose of determining any liability under the Securities Act of 1933, each such post-effective amendment shall be deemed to be a new registration statement relating to the securities offered therein, and the offering of such securities at that time shall be deemed to be the initial bona fide offering thereof.

(3) To remove from registration by means of a post-effective amendment any of the securities being registered which remain unsold at the termination of the offering.

(4) That, for the purpose of determining liability under the Securities Act to any purchaser,

(a) If the Company is relying on Rule 430B:

i. Each prospectus filed by the Company pursuant to Rule 424(b)(3) shall be deemed to be part of the registration statement as of the date the filed prospectus was deemed part of and included in the registration statement; and

ii. Each prospectus required to be filed pursuant to Rule 424(b)(2), (b)(5), or (b)(7) as part of a registration statement in reliance on Rule 430B relating to an offering made pursuant to Rule 415(a)(1)(i), (vii), or (x) for the purpose of providing the information required by section 10(a) of the Securities Act shall be deemed to be part of and included in the registration statement as of the earlier of the date such form of prospectus is first used after effectiveness or the date of the first contract of sale of securities in the offering described in the prospectus. As provided in Rule 430B, for liability purposes of the issuer and any person that is at that date an underwriter, such date shall be deemed to be a new effective date of the registration statement relating to the securities in the registration statement to which that prospectus relates, and the offering of such securities at that time shall be deemed to be the initial bona fide offering thereof; provided, however, that no statement made in a registration statement or prospectus that is part of the registration statement or made in a document incorporated or deemed incorporated by reference into the registration statement or prospectus that is part of the registration statement will, as to a purchaser with a time of contract of sale prior to such effective date, supersede or modify any statement that was made in the registration statement or prospectus that was part of the registration statement or made in any such document immediately prior to such effective date; or

(b) If the Company is subject to Rule 430C:

Each prospectus filed pursuant to Rule 424(b) as part of a registration statement relating to an offering, other than registration statements relying on Rule 430B or other than prospectuses filed in reliance on Rule 430A, shall be deemed to be part of and included in the registration statement as of the date it is first used after effectiveness; provided, however, that no statement made in a registration statement or prospectus that is part of the registration statement or made in a document incorporated or deemed incorporated by reference into the registration statement or prospectus that is part of the registration statement will, as to a purchaser with a time of contract of sale prior to such first use, supersede or modify any statement that was made in the registration statement or

prospectus that was part of the registration statement or made in any such document immediately prior to such date of first use.

(5) That, for the purpose of determining liability of the registrant under the Securities Act of 1933 to any purchaser in the initial distribution of securities: The undersigned registrant undertakes that in a primary offering of securities of the registrant pursuant to this registration statement, regardless of the underwriting method used to sell the securities to the purchaser, if the securities are offered or sold to such purchaser by means of any of the following communications, the undersigned registrant will be a seller to the purchaser and will be considered to offer and sell such securities to the purchaser: (i) any preliminary prospectus or prospectus of the undersigned registrant relating to the offering required to be filed pursuant to Rule 424; (ii) any free writing prospectus relating to the offering prepared by or on behalf of the undersigned registrant or used or referred to by the undersigned registrant; (iii) the portion of any other free writing prospectus relating to the offering containing material information about the undersigned registrant or its securities provided by or on behalf of the undersigned registrant; and (iv) Any other communication that is an offer in the offering made by the undersigned registrant to the purchaser.

(6) Insofar as Indemnification for liabilities arising under the Securities Act of 1933 may be permitted to directors, officers and controlling persons of the registrant pursuant to the foregoing provision, or otherwise, the registrant has been advised that in the opinion of the Securities and Exchange Commission such indemnification is against public policy as expressed in the Act and is, therefore, unenforceable. In the event that a claim for indemnification against such liabilities (other than the payment by the registrant of expenses incurred or paid by a director, officer or controlling person of the registrant in the successful defense of any action, suit or proceeding) is asserted by such director, officer or controlling person in connection with the securities being registered, the registrant will, unless in the opinion of its counsel the matter has been settled by controlling precedent, submit to a court of appropriate jurisdiction the question of whether such indemnification by it is against public policy as expressed in the Act and will be governed by the final adjudication of such issue.

SIGNATURES

In accordance with the requirements of the Securities Act of 1933, the registrant certifies that it has reasonable grounds to believe that it meets all of the requirements for filing on Form S-1 and authorized this registration statement to be signed on its behalf by the undersigned, in the City of Reno, Nevada on **March 22, 2010**.

Windstar, Inc.

By: /s/Siew Mee Fam

Siew Mee Fam

President, Chief Executive Officer, Principal Executive Officer,
Chief Financial Officer, Principal Financial Officer,
Principal Accounting Officer and Director

POWER OF ATTORNEY

KNOW ALL PERSONS BY THESE PRESENTS, that each person whose signature appears below constitutes and appoints Jennie Slade as his true and lawful attorney-in-fact and agent, with full power of substitution and re-substitution, for him and in his name, place and stead, in any and all capacities, to sign any and all amendments (including post-effective amendments) to this registration statement, and to file the same, with all exhibits thereto, and other documents in connection therewith, with the U.S. Securities and Exchange Commission, granting unto said attorney-in-fact and agent, full power and authority to do and perform each and every act and thing requisite and necessary to be done in connection therewith, as fully to all intents and purposes as he might or could do in person, hereby ratifying and confirming all that said attorney-in-fact and agent or any of them, or of their substitute or substitutes, may lawfully do or cause to be done by virtue hereof.

Pursuant to the requirements of the Securities Act, this registration statement has been signed by the following persons in the capacities and on the dates stated.

Windstar, Inc.

By: /s/Siew Mee Fam

Siew Mee Fam

President, Chief Executive Officer, Principal Executive Officer,
Chief Financial Officer, Principal Financial Officer,
Principal Accounting Officer and Director

By: /s/Sze Yein Wong

Sze Yein Wong

Director

March 22, 2010

March 20, 2010

CONSENT OF INDEPENDENT REGISTERED PUBLIC ACCOUNTING FIRM

Board of Directors
Windstar, Inc.
Ipoh, Perak, Malaysia

To Whom It May Concern:

Silberstein ungar, PLLC (formerly known as Maddox Ungar Silberstein, PLLC) hereby consents to the use in the Form S-1, (Post-Effective Amendment No. 2 to Form S-1) Registration Statement under the Securities Act of 1933, filed by Windstar, Inc. of our report dated January 6, 2010, relating to the financial statements of Windstar, Inc., a Nevada Corporation, as of and for the periods ending September 30, 2009 and 2008, and for the period from September 6, 2007 (inception) to September 30, 2009, and the reference to us under the caption "Interests of Named Experts and Counsel".

Sincerely,

/s/ Silberstein Ungar, PLLC

Silberstein Ungar, PLLC