

# REGENICIN, INC.

## FORM 10-K (Annual Report)

Filed 01/06/09 for the Period Ending 09/30/08

|             |  |
|-------------|--|
| Address     | 10 HIGH COURT<br>LITTLE FALLS, NJ 07424  |
| Telephone   | 646-403-3581   |
| CIK         | 0001412659   |
| Symbol      | RGIN   |
| SIC Code    | 3564 - Industrial and Commercial Fans and Blowers and Air Purification Equipment |
| Industry    | Biotechnology & Drugs  |
| Sector      | Healthcare   |
| Fiscal Year | 09/30  |

UNITED STATES  
SECURITIES AND EXCHANGE COMMISSION  
WASHINGTON, D.C. 20549

**FORM 10-K**

ANNUAL REPORT UNDER SECTION 13 OR 15(d) OF THE SECURITIES EXCHANGE ACT OF 1934

For the fiscal year ended September 30, 2008

TRANSITION REPORT UNDER SECTION 13 OR 15(d) OF THE SECURITIES EXCHANGE ACT

For the transition period from \_\_\_\_\_ to \_\_\_\_\_

Commission file number : **333-146834**

**Windstar, Inc.**

(Exact name of registrant as specified in its charter)

**Nevada**

(State or other jurisdiction of incorporation or organization)

**N/A**

(I.R.S. Employer Identification No.)

**No 47 Hala Pegoh,**

**Taman Sri Pengkalan 31650**

**Ipoh, Perak, Malaysia**

(Address of principal executive offices)

\_\_\_\_\_  
(Zip Code)

Registrant's telephone number: **(014) 327-4470**

Securities registered under Section 12(b) of the Exchange Act:

Title of each class

**none**

Name of each exchange on which registered

**not applicable**

Securities registered under Section 12(g) of the Exchange Act:

Title of each class

**none**

Name of each exchange on which registered

**not applicable**

Indicate by check mark if the registrant is a well-known seasoned issuer, as defined in Rule 405 of the Securities Act. **Yes**  **No**

Indicate by check mark if the registrant is not required to file reports pursuant to Section 13 or Section 15(d) of the Act. **Yes**  **No**

Check whether the Issuer (1) filed all reports required to be filed by Section 13 or 15(d) of the Securities Exchange Act during the past 12 months (or for such shorter period that the registrant was required to file such reports), and (2) has been subject to such filing requirements for the past 90 days. **Yes**  **No**

Indicate by check mark if disclosure of delinquent filers pursuant to Item 405 of Regulation S-K (§ 229.405 of this chapter) is not contained herein, and will not be contained, to the best of registrant's knowledge, in definitive proxy or information statements incorporated by reference in Part III of this Form 10-K or any amendment to this Form 10-K. **Yes**  **No**

Indicate by check mark whether the registrant is a large accelerated filer, an accelerated filer, a non-accelerated filer, or a smaller reporting company. See the definitions of "large accelerated filer," "accelerated filer" and "smaller reporting company" in Rule 12b-2 of the Exchange Act.

**Large accelerated filer**  **Accelerated filer**  **Non-accelerated filer**  **Smaller reporting company**

Indicate by check mark whether the registrant is a shell company (as defined in Rule 12b-2 of the Exchange Act). **Yes**  **No**

State the aggregate market value of the voting and non-voting common equity held by non-affiliates computed by reference to the price at which the common equity was last sold, or the average bid and asked price of such common equity, as of the last business day of the registrant's most recently completed second fiscal quarter. **Not available**

Indicate the number of shares outstanding of each of the registrant's classes of common stock, as of the latest practicable date. **2,150,000 as of September 30, 2008.**



**TABLE OF CONTENTS**Page**PART I**

|          |   |   |
|----------|---|---|
| Item 1.  | Business  | 3 |
| Item 1A. | Risk Factors  | 7 |
| Item 1B. | Unresolved Staff Comments                           | 8 |
| Item 2.  | Properties  | 8 |
| Item 3.  | Legal Proceedings                                   | 8 |
| Item 4.  | Submission of Matters to a Vote of Security Holders | 8 |

**PART II**

|          |   |    |
|----------|---|----|
| Item 5.  | Market for Registrant's Common Equity and Related Stockholder Matters and Issuer Purchases of Equity Securities | 8  |
| Item 6.  | Selected Financial Data   | 10 |
| Item 7.  | Management's Discussion and Analysis of Financial Condition and Results of Operations                           | 10 |
| Item 7A. | Quantitative and Qualitative Disclosures About Market Risk  | 15 |
| Item 8.  | Financial Statements and Supplementary Data   | 15 |
| Item 9.  | Changes In and Disagreements With Accountants on Accounting and Financial Disclosure                            | 15 |
| Item 9A. | Controls and Procedures (T).  | 15 |
| Item 9B. | Other Information   | 16 |

**PART III**

|          |  |    |
|----------|--|----|
| Item 10. | Directors, Executive Officers and Corporate Governance   | 16 |
| Item 11. | Executive Compensation   | 18 |
| Item 12. | Security Ownership of Certain Beneficial Owners and Management and Related Stockholder Matters | 18 |
| Item 13. | Certain Relationships and Related Transactions, and Director Independence                      | 20 |
| Item 14. | Principal Accountant Fees and Services   | 20 |

**PART IV**

|          |   |    |
|----------|---|----|
| Item 15. | Exhibits, Financial Statement Schedules | 22 |
|----------|---|----|

## **PART I**

### **Item 1. Business**

#### **Company Overview**

We were incorporated as “Windstar, Inc.” in the State of Nevada on September 6, 2007. We are engaged in the business of developing, producing, and marketing an effective and inexpensive air purification device.

Our goal is to produce an improved air purification device (our “Product”) specifically for removing the impurities produced while cooking, and for recycling and redistributing the cleansed air back into the kitchen. Our intention is to manufacture and distribute our Product to residential consumers in the Philippines and other Asian countries for everyday use in their homes.

We are a development stage company and have not generated any sales to date. Our product is still in the development stage and is not yet ready for commercial sale. We plan to complete the development of our product in the next six to twelve months, and begin recognizing revenue from the distribution of our product by April, 2009.

#### **The Market for our Product**

In many Asian countries, the standard of living has been steadily increasing for the average citizen as a result of recent economic and political stability. As a result, more families are enjoying the benefits of single residence homes, many of which include a separate kitchen area for food preparation. Although the standard of living has been rising, most Asian families still rely on traditional dietary staples (fried rice, vegetables and various cuts of meat) to feed their families. The preparation of these popular dietary choices historically involves the ingredients being fried in some type of cooking oil, either in a wok or a skillet, over a large stove-top flame.

The preparation of a typical Asian meal, particularly on a hot stove, produces an exorbitant amount of harsh airborne by-products that can adversely affect the air quality in the surrounding space, specifically the kitchen. Once infiltrated by these impurities, the kitchen air may contain large amounts of particulate-laden steam, smoke, fats, oils, noxious odors and other chemicals.

We have reviewed current air purification systems available in Asia markets, with the exception of Japan, in which we do not intend to operate. Most Asian kitchens are equipped with a single fan, usually stationed above the stove area, to remove any smoke and impurities created in the cooking process. These fans, however, are largely ineffective and do little more than recirculate the polluted air. Fans are not effective at improving the overall air quality in the room, nor do they reduce any distasteful odors that may be produced while cooking. Most specialized air purification systems available in Asia require the installation of expensive systems of fans, vents, and filters throughout the kitchen, which is inconvenient and impractical for residential consumers. Other self-contained purification products similar to ours are only effective at removing one or two contaminants from the air, and do not address the wide variety of impurities and odors created by cooking. Our product uses a myriad of filters and methods for removing particulate matter, reducing odors, and cleansing the air.

## Air Purification Methods

There are two main methods for disposing of the impurities that commonly infiltrate the air during cooking. The first type of system simply removes the impure air from the kitchen and transports it through vents for release into the atmosphere. However, venting the impure air to the outside requires the installation of an expensive and cumbersome system of filters and vents, which is not a practical solution for most residential kitchens. Additionally, it is believed that releasing the impure air to the atmosphere can decrease air quality in the immediate vicinity, which is inconvenient and may even be restricted in some areas.

The second type of air purification system suctions the impure air, cleanses it, and then returns it to the kitchen in a cyclical process. This system only requires the installation of a single, self-contained air purification device in the kitchen area, where the air is most likely to be affected by cooking by-products. We have focused the development of our Product on this system because it is simple, practical, and cost-effective for the residential consumer.

Among the systems that cleanse and recycle the air, several different processes of varying effectiveness can be used for air purification. Most of the processes are effective at cleansing the air of a particular contaminant. The most commonly used processes are:

- 1) **Filter-based** . A filter based purification system suctions the impure air and forces it through a filter to physically trap airborne particles. Most filters are effective at trapping all particulates that are larger than a particular size. For example, HEPA (High Efficiency Particulate Air) filters are most effective at trapping particles that are 0.3 micrometers in size or larger. Some more advanced HEPA filters may even trap particles as small as 0.01 micrometers.
- 2) **Activated Carbon**. Activated carbon is a highly porous material that can absorb volatile chemicals on a molecular basis, and is effective at removing volatile organic compounds, chemicals and strong odors from the air. Activated carbon can be used alone or in conjunction with other filter technology.
- 3) **Ionization**. Ionizer purifiers use charged electrical surfaces to generate electrically charged ions. These ions attach to airborne particles which are then electrostatically attracted to a charged collector plate, thus removing the pollutants from the air.

## Our Product

We are in the process of developing an air purification device that is both easily manufactured and very effective at cleansing the impure air that results from cooking in home kitchens. Our product is particularly useful for cleansing the air of odors, smoke, particulates, and other by-products of Asian-style cooking techniques employed with stoves, ovens, or indoor grilles.

Our Product is a self-contained air purification system that utilizes a four-stage process to remove particulate matter, decrease smoke vapors, and cut down on noxious odors created by common Asian cooking methods. Our Product differs from others currently available in the market because the four-stage process allows for the optimum removal of an array of contaminants, including particulate matter, heavy smoke, and odors, as follows:

- 1) Air initially passes through the first stage of our air purification system, which is a filter net, designed to trap particulate matter as small as 0.3 micrometers, in much the same way and to a similar degree as a HEPA filter. Our system uses an updraft vent to collect the impure air and force it into our filtration device. We are currently investigating the incorporation of a fan to draw the impure air into our Product. We will assess the advantages, such as increased volume and efficiency, and disadvantages, such as increased noise, required power to operate, and expense to manufacture, before deciding if a fan-based system is warranted.
- 2) In the second stage of our system filtered air is passed through an ionization unit. Here the air will be further purified of particulate matter by using electrically charged ions to attract airborne particles and trap them on a charged electrical surface.
- 3) The third stage of our system is an oil collection device, which removes heavy grease and oil particles that are produced by cooking fatty foods over high flames, and collects the substances in a special collection tray, which can be easily removed, cleaned, or replaced as necessary.
- 4) The fourth and final stage of our system is an activated carbon filter, which rids the air of odors by absorbing any remaining volatile compounds on a molecular level.

As air flows through our Product, it is filtered and purified multiple times, using a variety of methods to remove as many contaminants as possible before recirculating the recycled air back into the kitchen.

A distinct benefit of our Product is that the filters essential to each stage of purification are contained separately within the unit in special filtration “drawers,” which are easy to access. This gives the consumer the ability to remove the filtration units individually to clean or replace them without needing to remove or replace the entire unit. The diagram below illustrates the Product and its component pieces.

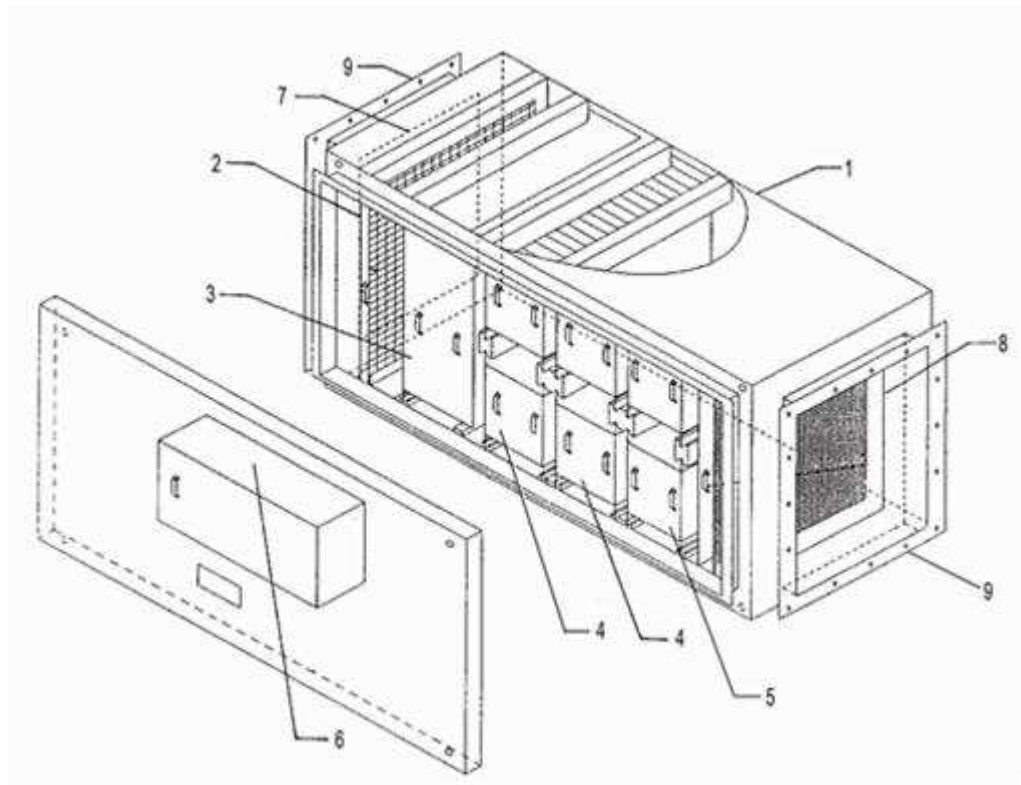

*Diagram 1*

1. Case
2. Filter Unit
3. Ionization Unit
4. Oil Collectors
5. Activated Carbon Unit
6. Power Supply
7. Air Inlet Port
8. Air Outlet (Exhaust) Port
9. Smoke Pipe Connectors

## **Competition**

We face some competition in the development, production, and marketing of air filtration devices. Other companies in this field are established manufacturers who sell air filtration devices in many countries around the world. These companies enjoy brand recognition which exceeds that of our brand name. We compete with several manufacturers, importers and distributors who have significantly greater financial, distribution, advertising and marketing resources than we do. We intend to compete primarily on the basis of quality, brand name recognition and price. Also, we are developing our Product specifically for homeowners in the Philippines and other Asian countries

We believe that our success will depend upon our ability to remain competitive in our product area. The failure to compete successfully in the future could result in a material deterioration of customer loyalty and our image and could have a material adverse effect on our business.

## **Intellectual Property**

We intend to aggressively assert our rights under trade secret, unfair competition, trademark and copyright laws in the Philippines and the Asian countries in which we plan to do business to protect our intellectual property, including product formulas, proprietary manufacturing processes and technologies, product research and concepts and recognized trademarks. These rights are protected through the acquisition of patents and trademark registrations, the maintenance of trade secrets, the development of trade dress, and, where appropriate, litigation against those who are, in our opinion, infringing these rights.



### *Brand Recognition*

We have selected the name of our company in an attempt to establish our brand name. Although our name and logo are not trademarked at this time, we anticipate the necessity of a trademark upon successful commercialization of our Product in order to protect our brand integrity.

### *Patents*

We are in the process of researching patent rights, and at present we are not aware of anyone in Asia or the Philippines having any patents, trademarks and/or copyright protection for this or any similar product. Upon successful completion of the development of our Product, we plan to apply for patent protection and/or copyright protection in the Philippines, and other jurisdictions in which we conduct business and distribute our product.

### **Government Regulation and Supervision**

We are subject to the laws and regulations of those jurisdictions in which we plan to sell our product, which are generally applicable to business operations, such as business licensing requirements, income taxes and payroll taxes. In general, the sale of our product in the Philippines is not subject to special regulatory and/or supervisory requirements.

### **Employees**

We have no other employees other than our officers and directors. If finances permit, however, we intend on employing sales representatives in the Philippines when our product is ready for production and shipping.

### **Research and Development Expenditures**

We have not incurred any research or development expenditures since our incorporation.

### **Subsidiaries**

We have neither formed, nor purchased any subsidiaries since our incorporation.

### **Item 1A. Risk Factors.**

A smaller reporting company is not required to provide the information required by this Item.

**Item 1B. Unresolved Staff Comments**

A smaller reporting company is not required to provide the information required by this Item.

**Item 2. Properties**

Our operations office is located at No. 47 Hala Pegoh, 8 Taman Sri Pengkalan 31650, Ipoh, Perak, Malaysia. We do not lease or own any real property. Our offices are provided free of charge by Siew Mee Fam, our officer and director.

**Item 3. Legal Proceedings**

We are not a party to any pending legal proceeding. We are not aware of any pending legal proceeding to which any of our officers, directors, or any beneficial holders of 5% or more of our voting securities are adverse to us or have a material interest adverse to us.

**Item 4. Submission of Matters to a Vote of Security Holders**

No matters were submitted to a vote of the Company's shareholders during the fiscal year ended September 30, 2008.

**PART II**

**Item 5. Market for Registrant's Common Equity and Related Stockholder Matters and Issuer Purchases of Equity Securities**

**Market Information**

Our common stock is currently quoted on the OTC Bulletin Board ("OTCBB"), which is sponsored by FINRA. The OTCBB is a network of security dealers who buy and sell stock. The dealers are connected by a computer network that provides information on current "bids" and "asks", as well as volume information. Our shares are quoted on the OTCBB under the symbol "WDST."

The following table sets forth the range of high and low bid quotations for our common stock for each of the periods indicated as reported by the OTCBB. These quotations reflect inter-dealer prices, without retail mark-up, mark-down or commission and may not necessarily represent actual transactions.

| Fiscal Year Ending September 30, 2008 |         |        |
|---------------------------------------|---------|--------|
| Quarter Ended                         | High \$ | Low \$ |
| September 30, 2008                    | N/A     | N/A    |
| June 30, 2008                         | N/A     | N/A    |
| March 31, 2008                        | N/A     | N/A    |
| December 31, 2007                     | N/A     | N/A    |

| Fiscal Year Ending September 30, 2007 |         |        |
|---------------------------------------|---------|--------|
| Quarter Ended                         | High \$ | Low \$ |
| September 30, 2007                    | N/A     | N/A    |
| June 30, 2007                         | N/A     | N/A    |
| March 31, 2007                        | N/A     | N/A    |
| December 31, 2006                     | N/A     | N/A    |

### Penny Stock

The SEC has adopted rules that regulate broker-dealer practices in connection with transactions in penny stocks. Penny stocks are generally equity securities with a market price of less than \$5.00, other than securities registered on certain national securities exchanges or quoted on the NASDAQ system, provided that current price and volume information with respect to transactions in such securities is provided by the exchange or system. The penny stock rules require a broker-dealer, prior to a transaction in a penny stock, to deliver a standardized risk disclosure document prepared by the SEC, that: (a) contains a description of the nature and level of risk in the market for penny stocks in both public offerings and secondary trading; (b) contains a description of the broker's or dealer's duties to the customer and of the rights and remedies available to the customer with respect to a violation of such duties or other requirements of the securities laws; (c) contains a brief, clear, narrative description of a dealer market, including bid and ask prices for penny stocks and the significance of the spread between the bid and ask price; (d) contains a toll-free telephone number for inquiries on disciplinary actions; (e) defines significant terms in the disclosure document or in the conduct of trading in penny stocks; and (f) contains such other information and is in such form, including language, type size and format, as the SEC shall require by rule or regulation.

The broker-dealer also must provide, prior to effecting any transaction in a penny stock, the customer with (a) bid and offer quotations for the penny stock; (b) the compensation of the broker-dealer and its salesperson in the transaction; (c) the number of shares to which such bid and ask prices apply, or other comparable information relating to the depth and liquidity of the market for such stock; and (d) a monthly account statement showing the market value of each penny stock held in the customer's account.

In addition, the penny stock rules require that prior to a transaction in a penny stock not otherwise exempt from those rules, the broker-dealer must make a special written determination that the penny stock is a suitable investment for the purchaser and receive the purchaser's written acknowledgment of the receipt of a risk disclosure statement, a written agreement as to transactions involving penny stocks, and a signed and dated copy of a written suitability statement.

These disclosure requirements may have the effect of reducing the trading activity for our common stock. Therefore, stockholders may have difficulty selling our securities.

## **Holders of Our Common Stock**

As of September 30, 2008, we had forty (40) shareholders of record.

## **Dividends**

There are no restrictions in our articles of incorporation or bylaws that prevent us from declaring dividends. The Nevada Revised Statutes, however, do prohibit us from declaring dividends where after giving effect to the distribution of the dividend:

1. we would not be able to pay our debts as they become due in the usual course of business, or;
2. our total assets would be less than the sum of our total liabilities plus the amount that would be needed to satisfy the rights of shareholders who have preferential rights superior to those receiving the distribution.

We have not declared any dividends and we do not plan to declare any dividends in the foreseeable future.

## **Securities Authorized for Issuance under Equity Compensation Plans**

We do not have any equity compensation plans.

## **Item 6. Selected Financial Data**

A smaller reporting company is not required to provide the information required by this Item.

## **Item 7. Management’s Discussion and Analysis of Financial Condition and Results of Operations**

### **Forward-Looking Statements**

Certain statements, other than purely historical information, including estimates, projections, statements relating to our business plans, objectives, and expected operating results, and the assumptions upon which those statements are based, are “forward-looking statements” within the meaning of the Private Securities Litigation Reform Act of 1995, Section 27A of the Securities Act of 1933 and Section 21E of the Securities Exchange Act of 1934. These forward-looking statements generally are identified by the words “believes,” “project,” “expects,” “anticipates,” “estimates,” “intends,” “strategy,” “plan,” “may,” “will,” “would,” “will be,” “will continue,” “will likely result,” and similar expressions. We intend such forward-looking statements to be covered by the safe-harbor provisions for forward-looking statements contained in the Private Securities Litigation Reform Act of 1995, and are including this statement for purposes of complying with those safe-harbor provisions. Forward-looking statements are based on current expectations and assumptions that are subject to risks and uncertainties which may cause actual results to differ materially from the forward-looking statements. Our ability to predict results or the actual effect of future plans or strategies is inherently uncertain. Factors which could have a material adverse affect on our operations and future prospects on a consolidated basis include, but are not limited to: changes in economic conditions, legislative/regulatory changes, availability of capital, interest rates, competition, and generally accepted accounting principles. These risks and uncertainties should also be considered in evaluating forward-looking statements and undue reliance should not be placed on such statements. We undertake no obligation to update or revise publicly any forward-looking statements, whether as a result of new information, future events or otherwise. Further information concerning our business, including additional factors that could materially affect our financial results, is included herein and in our other filings with the SEC.

## **Plan of Operation in the Next Twelve Months**

### ***Product Development***

Our company's goal is to produce an air purification device that is available to the public at a price of \$20 per unit, so as not to create a financial hardship on families who would like cleaner kitchen air. We will achieve this goal by continuing to develop our product using the best materials and methods available to achieve the highest quality product at the lowest possible production cost.

We intend to continue to test and refine the design of the prototype of our Product over the coming months. While we feel that our Product in its current form could compete effectively in the marketplace, we plan to improve the design of our Product to improve its filtration efficiency and reduce its production cost as much as possible. Specifically, we are looking to achieve the following:

- Creating the most effective purification system using the least amount of space;
- Making our product quieter and more energy efficient, to reduce consumer cost;
- Selecting the best materials available at the lowest cost possible

Depending upon the success of our initial product, in the future we intend to add additional components to give consumers more options and increase demand for our products. We expect to incur roughly \$10,000 on product development in the next twelve months.

### ***Production and Distribution***

We do not currently have any manufacturing facilities. Our directors have contacted several general manufacturers in the Philippines, and have begun negotiations for the manufacture of our product on a contract basis. We are currently negotiating price, payment, customer guarantee, shipping, inventory, delivery schedule and returns. Production of our Product doesn't require any facilities or equipment beyond what is available at any general manufacturer. We could contract with any general manufacturer to manufacture our product by following our instructions. Most manufacturers already utilize the same materials we use to create our Product, we simply need to provide the design and manufacturing instructions. We do not anticipate renting a warehouse at this stage of our business. The manufacturer we select to work with us will provide packaging, storage, and shipping services for us as part of our agreement.

We intend to sell our product in wholesale orders to large kitchen, home appliance, and residential construction companies. Upon receiving a wholesale order, we will arrange for manufacture and shipment of the Product to the customer at pre-negotiated prices from the manufacturer. We anticipate wholesale orders will be fulfilled within five business days of placing the order to the manufacturer. Our Product will arrive at the customer fully assembled, with easy-to-follow instructions for installation and use. As a result, production of our air purifiers will not require us to procure any special facilities or equipment.

### ***Marketing Strategy***

The goal of our company is for our air purification system to become the leading air purification product in Asia. In order to achieve our goal, we intend to complete the development of our initial product and introduce our product to the kitchen and home appliance industries within the next twelve months. To increase consumer awareness of our product among our potential customers, specifically major kitchen retailers, we intend to specifically engage in the following:

- **Attending National and Regional Kitchen and Home Appliance Promotions, Events and Conferences:** These are events and conferences managed by regional and central home appliance organizations to promote new kitchen products and technology. We plan to introduce our products to the home appliance merchants, retailers and wholesalers in attendance at these events. These events will also include trade meetings and promotional events and related seminars and conferences.
- **Developing Direct Marketing Programs to Attract Retailers:** We intend to market directly to retailers by conducting seminars, through the use of online advertisements, and through traditional media outlets such as newspapers and trade publications.
- **Special Promotions:** Initially, we intend to offer special promotions to a few major home appliance retailers by supplying them with a limited amount of our Product for sale or distribution to their general customers. Based on customer feedback, we anticipate these retailers will begin placing regular, wholesale orders with our company.
- **Product Demonstrations:** We intend to send members of our sale team to various kitchen and home appliance supply stores and retailers to conduct live demonstrations of our product, including assembly, installation, and effectiveness.

We anticipate that the costs associated with our initial marketing program will be approximately \$6,000. Additional Travel expenses associated with the development, production, and marketing of our Product are expected to be approximately \$4,000.

### ***Management Expansion***

We intend to expand our current management team to retain directors, officers and employees with experience relevant to our business focus. Our current officers are highly skilled in technical areas such as research and product development, and we are looking to add officers who have experience in marketing and business management to expand our company more effectively.

### ***Sales Personnel***

In the short term, we intend to use the services of our management to sell our products. As our product approaches the manufacturing stage, however, we plan to employ salespersons in the Philippines, and other Asian countries to promote and sell our Product. These sales representatives will be responsible for soliciting, selecting and securing accounts within a particular regional territory.

### ***Expenses***

We estimate the costs to implement our business strategy over the following twelve months to be:

- Travel and Related expenses, which will consist primarily of our executive officers and directors visiting home appliance merchants, retailers and wholesalers in their sales efforts. We estimate travel and related expenses for the next twelve months will be approximately \$4,000;
- Initial Marketing, which will consist of the marketing efforts discussed above, including direct marketing and attendance at trade shows. We estimate initial marketing expenses for the next twelve months will be approximately \$6,000;
- Research and Development costs consist of developing and testing our Product and determining the best combination of materials and suppliers for production. We estimate that research and development costs for the next twelve months will be approximately \$10,000.

We intend to obtain business capital through the use of private equity fundraising or shareholder loans. We anticipate that, in time, the primary source of revenues for our business model will be the sale of our Product.

### ***Significant Equipment***

We do not intend to purchase any significant equipment for the next twelve months.

### **Results of Operations for the Years Ended September 30, 2008 and 2007, and for the period from Inception until September 30, 2008.**

We have not earned any revenues since our inception on September 6, 2007. We do not anticipate earning revenues until such time that we refine our Product and successfully market it to our target consumers. We are presently in the development stage of our business and we can provide no assurance that we will successfully implement our business plan.

We incurred operating expenses in the amount of \$44,500 for the year ended September 30, 2008, compared with \$4,000 for the year ended September 30, 2007. The entire amount for both periods was attributable to professional fees. We have incurred total operating expenses of \$48,500 from inception on September 6, 2007 through September 30, 2008. The entire amount was attributable to professional fees.

We anticipate our operating expenses will increase as we undertake our plan of operations. The increase will be attributable to the continued development of our Product and the professional fees associated with our becoming a reporting company under the Securities Exchange Act of 1934.

We incurred a net loss of \$44,500 for the year ended September 30, 2008, compared with \$4,000 for the year ended September 30, 2007. We incurred a total net loss of \$48,500 from inception on September 6, 2007 through September 30, 2008. Our losses for all periods are attributable to operating expenses together with a lack of any revenues.

### **Liquidity and Capital Resources**

As of September 30, 2008, we had no current assets. We had \$5,500 in current liabilities as of September 30, 2008. Thus, we have a working capital deficit of \$5,500 as of September 30, 2008.

Operating activities used \$43,000 in cash for the period from September 6, 2007 (Date of Inception) until September 30, 2008. Our net loss of \$48,500 represented the causal factor of our negative operating cash flow offset by accrued expenses of \$5,500. Financing Activities during the period from September 6, 2007 (Date of Inception) until September 30, 2008 generated \$43,000 in cash.

As of September 30, 2008, we have insufficient cash to operate our business at the current level for the next twelve months and insufficient cash to achieve our business goals. The success of our business plan beyond the next 12 months is contingent upon us obtaining additional financing. We intend to fund operations through debt and/or equity financing arrangements, which may be insufficient to fund our capital expenditures, working capital, or other cash requirements. We do not have any formal commitments or arrangements for the sales of stock or the advancement or loan of funds at this time. There can be no assurance that such additional financing will be available to us on acceptable terms, or at all.

### **Going Concern**

We have negative working capital and have not yet received revenues from sales of products or services. These factors create substantial doubt about our ability to continue as a going concern. The financial statements contained herein do not include any adjustment that might be necessary if we are unable to continue as a going concern.

Our ability to continue as a going concern is dependent on our generating cash from the sale of our common stock and/or obtaining debt financing and attaining future profitable operations. Management's plans include selling our equity securities and obtaining debt financing to fund out capital requirement and ongoing operations; however, there can be no assurance we will be successful in these efforts.



## **Off Balance Sheet Arrangements**

As of September 30, 2008, there were no off balance sheet arrangements.

## **Recently Issued Accounting Pronouncements**

We do not expect the adoption of recently issued accounting pronouncements to have a significant impact on our results of operations, financial position or cash flow.

## **Item 7A. Quantitative and Qualitative Disclosures About Market Risk**

A smaller reporting company is not required to provide the information required by this Item.

## **Item 8. Financial Statements and Supplementary Data**

See the financial statements annexed to this annual report.

## **Item 9. Changes In and Disagreements with Accountants on Accounting and Financial Disclosure**

No events occurred requiring disclosure under Item 307 and 308 of Regulation S-K during the fiscal year ending September 30, 2008.

## **Item 9A(T). Controls and Procedures**

Disclosure controls and procedures are controls and other procedures that are designed to ensure that information required to be disclosed in company reports filed or submitted under the Securities Exchange Act of 1934 (the "Exchange Act") is recorded, processed, summarized and reported, within the time periods specified in the Securities and Exchange Commission's rules and forms. Disclosure controls and procedures include without limitation, controls and procedures designed to ensure that information required to be disclosed in company reports filed or submitted under the Exchange Act is accumulated and communicated to management, including our chief executive officer and treasurer, as appropriate to allow timely decisions regarding required disclosure.

As required by Rules 13a-15 and 15d-15 under the Exchange Act, our chief executive officer and chief financial officer carried out an evaluation of the effectiveness of the design and operation of our disclosure controls and procedures as of September 30, 2008. Based on their evaluation, they concluded that our disclosure controls and procedures were effective.

Our internal control over financial reporting is a process designed by, or under the supervision of, our chief executive officer and chief financial officer and effected by our board of directors, management and other personnel, to provide reasonable assurance regarding the reliability of our financial reporting and the preparation of our financial statements for external purposes in accordance with generally accepted accounting principles. Internal control over financial reporting includes policies and procedures that pertain to the maintenance of records that in reasonable detail accurately and fairly reflect the transactions and dispositions of our assets; provide reasonable assurance that transactions are recorded as necessary to permit preparation of our financial statements in accordance with generally accepted accounting principles, and that our receipts and expenditures are being made only in accordance with the authorization of our board of directors and management; and provide reasonable assurance regarding prevention or timely detection of unauthorized acquisition, use or disposition of our assets that could have a material effect on our financial statements.

Under the supervision and with the participation of our management, including our chief executive officer, we conducted an evaluation of the effectiveness of our internal control over financial reporting based on the criteria established in Internal Control – Integrated Framework issued by the Committee of Sponsoring Organizations of the Treadway Commission (“COSO”). Based on this evaluation under the criteria established in Internal Control – Integrated Framework, our management concluded that our internal control over financial reporting was effective as of September 30, 2008.

This annual report does not include an attestation report of our registered public accounting firm regarding internal control over financial reporting. Management’s report was not subject to attestation by our registered public accounting firm pursuant to temporary rules of the Securities and Exchange Commission that permit us to provide only management’s report in this annual report.

During the most recently completed fiscal quarter, there has been no change in our internal control over financial reporting that has materially affected or is reasonably likely to materially affect, our internal control over financial reporting.

**Item 9B. Other Information**

None

**PART III**

**Item 10. Directors, Executive Officers and Corporate Governance**

The following information sets forth the name of our executive officers and directors, their ages as of September 30, 2008, and their present position.

| <u>Name</u>   | <u>Age</u> | <u>Position Held with the Company</u>  |
|---|------------|--|
| Siew Mee Fam<br>No 47 Hala Pegoh,<br>8 Taman Sri Pengkalan<br>31650<br>Ipoh, Perak, Malaysia  | 25         | President, Chief Executive Officer, Principal Executive Officer, Chief Financial Officer, Principal Financial Officer, Principal Accounting Officer and Director |
| Sze Yein Wong<br>No 47 Hala Pegoh,<br>8 Taman Sri Pengkalan<br>31650<br>Ipoh, Perak, Malaysia | 25         | Director   |

Set forth below is a brief description of the background and business experience of our sole executive officer and director.

**Siew Mee Fam** is our President, Chief Executive Officer, Principal Executive Officer, Chief Financial Officer, Principal Financial Officer, Principal Accounting Officer and Director. Siew Mee Fam obtained a Bachelor of Arts from HELP University College in Pusat Bandar Damansara, Malaysia in March of 2002, and has worked as a Public Relations Specialist for Salient Synergy Sdn. Bhd. since 2002.

**Sze Yein Wong** is one of our directors. Siew Mee Fam obtained a Bachelor of Science Degree from Universiti Putra Malaysia (UPM), Serdang in April of 2002, and has worked as an Engineer for General Electric, Inc. since 2002.

### **Term of Office**

Our Directors are appointed for a one-year term to hold office until the next annual general meeting of our shareholders or until removed from office in accordance with our bylaws. Our officers are appointed by our board of directors and hold office until removed by the board.

### **Significant Employees**

We do not currently have any significant employees aside from Siew Mee Fam and Sze Yein Wong.

We conduct our business through agreements with consultants and arms-length third parties. Current arrangements in place include the following:

1. Verbal agreements with our accountants to perform requested financial accounting services.
2. Verbal agreements with auditors to perform audit functions at their respective normal and customary rates.

We understand that enforcing verbal relationships is difficult and less preferred than having written agreements where the terms and conditions are set forth clearly. At this stage of our existence, however, we choose not to draft documents to memorialize some of our arrangements, since we cannot afford involving counsel at expensive rates. We do and will use written arrangements and counsel advice to the extent financially permissible.

**Involvement in Certain Legal Proceedings**

To the best of our knowledge, during the past five years, none of the following occurred with respect to our present or former director, executive officer, or employee: (1) any bankruptcy petition filed by or against any business of which such person was a general partner or executive officer either at the time of the bankruptcy or within two years prior to that time; (2) any conviction in a criminal proceeding or being subject to a pending criminal proceeding (excluding traffic violations and other minor offenses); (3) being subject to any order, judgment or decree, not subsequently reversed, suspended or vacated, of any court of competent jurisdiction, permanently or temporarily enjoining, barring, suspending or otherwise limiting his or her involvement in any type of business, securities or banking activities; and (4) being found by a court of competent jurisdiction (in a civil action), the SEC or the Commodities Futures Trading Commission to have violated a federal or state securities or commodities law, and the judgment has not been reversed, suspended or vacated.

**Audit Committee**

We do not have a separately-designated standing audit committee. The entire Board of Directors performs the functions of an audit committee, but no written charter governs the actions of the Board when performing the functions of what would generally be performed by an audit committee. The Board approves the selection of our independent accountants and meets and

**Code of Ethics**

As of September 30, 2008, we had not adopted a Code of Ethics for Financial Executives, which would include our principal executive officer, principal financial officer, principal accounting officer or controller, or persons performing similar functions.

**Item 11. Executive Compensation**

**Summary Compensation Table**

The table below summarizes all compensation awarded to, earned by, or paid to both to our officers and to our directors for all services rendered in all capacities to us for our fiscal years ended September 30, 2008 and 2007.

| SUMMARY COMPENSATION TABLE   |      |             |            |                   |                    |                                  |                                     |                   |            |
|--|------|-------------|------------|-------------------|--------------------|----------------------------------|-------------------------------------|-------------------|------------|
| Name and principal position  | Year | Salary (\$) | Bonus (\$) | Stock Awards (\$) | Option Awards (\$) | Non-Equity                       | Nonqualified                        | All Other         | Total (\$) |
|  |      |             |            |                   |                    | Incentive Plan Compensation (\$) | Deferred Compensation Earnings (\$) | Compensation (\$) |            |
| <b>Siew Mee Fam</b><br>President,<br>Chief Executive Officer,<br>Principal Executive Officer,<br>Chief Financial Officer,<br>Principal Financial Officer,<br>Principal Accounting Officer and Director | 2008 | 0           | 0          | 0                 | 0                  | 0                                | 0                                   | 0                 | 0          |
|  | 2007 | 0           | 0          | 0                 | 0                  | 0                                | 0                                   | 0                 | 0          |

**Narrative Disclosure to the Summary Compensation Table**

We have not entered into any employment agreement or consulting agreement with our executive officers. There are no arrangements or plans in which we provide pension, retirement or similar benefits for executive officers.

Although we do not currently compensate our officers, we reserve the right to provide compensation at some time in the future. Our decision to compensate officers depends on the availability of our cash resources with respect to the need for cash to further our business purposes.

**Outstanding Equity Awards at Fiscal Year-End**

The table below summarizes all unexercised options, stock that has not vested, and equity incentive plan awards for each named executive officer as of September 30, 2008.

| <b>OUTSTANDING EQUITY AWARDS AT FISCAL YEAR-END</b> |   |   |   |                     |                 |   |              |  |   |
|---|---|---|---|---------------------|-----------------|---|--------------|--|---|
|   | <b>OPTION AWARDS</b>  |   |   |                     |                 | <b>STOCK AWARDS</b>   |              |  |   |
| Name  | Number of Securities Underlying Unexercised Options (#) Exercisable | Number of Securities Underlying Unexercised Options (#) Unexercisable | Equity Incentive Plan Awards: Number of Securities Underlying Unexercised Options (#) | Exercise Price (\$) | Expiration Date | Number of Shares or Units of Stock That Have Not Vested (#) | Market Value | Number of Shares, Units or Rights That Have Not Vested (#) | Equity Incentive Plan Awards: Market or Payout Value of Unearned Shares, Units or Rights That Have Not Vested (#) |
| Siew Mee Fam  | -   | -   | -   | -                   | -               | -   | -            | -  | -   |

## Stock Option Grants

We have not granted any stock options to the executive officers or directors since our inception.

## Director Compensation

The table below summarizes all compensation awarded to, earned by, or paid to our directors for all services rendered in all capacities to us for the period from inception through September 30, 2008.

| <b>DIRECTOR COMPENSATION</b> |  |                         |                          |   |   |                                      |               |
|------------------------------|--|-------------------------|--------------------------|---|---|--------------------------------------|---------------|
| Name                         | Fees<br>Earned or<br>Paid in<br>Cash<br>(\$) | Stock<br>Awards<br>(\$) | Option<br>Awards<br>(\$) | Non-Equity<br>Incentive<br>Plan<br>Compensation<br>(\$) | Non-Qualified<br>Deferred<br>Compensation<br>Earnings<br>(\$) | All<br>Other<br>Compensation<br>(\$) | Total<br>(\$) |
| Sze Yein<br>Wong             | 0  | 0                       | 0                        | 0   | 0   | 0                                    | 0             |

### Narrative Disclosure to the Director Compensation Table

We do not pay any compensation to our directors at this time. However, we reserve the right to compensate our directors in the future with cash, stock, options, or some combination of the above.

We have not reimbursed our directors for expenses incurred in connection with attending board meetings nor have we paid any directors fees or other cash compensation for services rendered as a director in the year ended September 30, 2008.

### Stock Option Plans

We did not have a stock option plan as of September 30, 2008

### Item 12. Security Ownership of Certain Beneficial Owners and Management and Related Stockholder Matters

The following table sets forth, as of September 30, 2008, certain information as to shares of our common stock owned by (i) each person known by us to beneficially own more than 5% of our outstanding common stock, (ii) each of our directors, and (iii) all of our executive officers and directors as a group:

| <u>Name and Address of Beneficial Owners of Common Stock</u>   | <u>Title of Class</u> | <u>Amount and Nature of Beneficial Ownership</u> <sup>1</sup> | <u>% of Common Stock</u> <sup>2</sup> |
|--|-----------------------|---|---------------------------------------|
| Siew Mee Fam<br>No 47 Hala Pegoh,<br>No 47 Hala Pegoh,<br>8 Taman Sri Pengkalan 31650<br>Ipoh, Perak, Malaysia | Common<br>Stock       | 600,000   | 27.9%                                 |
| Sze Yein Wong<br>No 47 Hala Pegoh,<br>8 Taman Sri Pengkalan 31650<br>Ipoh, Perak, Malaysia                     | Common<br>Stock       | 600,000   | 27.9%                                 |
| <b>DIRECTORS AND OFFICERS – TOTAL</b>  |                       | <b>1,200,000</b>  | <b>55.8%</b>                          |
| <b>5% SHAREHOLDERS</b>   |                       |   |                                       |
| NONE   | Common<br>Stock       | NONE  | NONE                                  |

- As used in this table, "beneficial ownership" means the sole or shared power to vote, or to direct the voting of, a security, or the sole or shared investment power with respect to a security (i.e., the power to dispose of, or to direct the disposition of, a security). In addition, for purposes of this table, a person is deemed, as of any date, to have "beneficial ownership" of any security that such person has the right to acquire within 60 days after such date.
- The percentage shown is based on denominator of 2,150,000 shares of common stock issued and outstanding for the company as of September 30, 2008.

### Item 13. Certain Relationships and Related Transactions, and Director Independence

None of our directors or executive officers, nor any proposed nominee for election as a director, nor any person who beneficially owns, directly or indirectly, shares carrying more than 5% of the voting rights attached to all of our outstanding shares, nor any members of the immediate family (including spouse, parents, children, siblings, and in-laws) of any of the foregoing persons has any material interest, direct or indirect, in any transaction over the last two years or in any presently proposed transaction which, in either case, has or will materially affect us.

### Item 14. Principal Accounting Fees and Services

Below is the table of Audit Fees (amounts in US\$) billed by our auditor in connection with the audit of the Company's annual financial statements for the years ended:

| Financial Statements<br>for the<br><u>Year Ended September</u><br>30 | <u>Audit</u><br><u>Services</u> | <u>Audit Related</u><br><u>Fees</u> | <u>Tax Fees</u> | <u>Other</u><br><u>Fees</u> |
|--|---------------------------------|-------------------------------------|-----------------|-----------------------------|
| 2008   | \$9500                          |                                     |                 |                             |
| 2007   | \$4000                          |                                     |                 |                             |

**PART IV****Item 15. Exhibits, Financial Statements Schedules**

Index to Financial Statements Required by Article 8 of Regulation S-X:

**Audited Financial Statements:**

- F-1 Report of Independent Registered Public Accounting Firm
- F-2 Consolidated Balance Sheets as of September 30, 2008 and 2007;
- F-3 Statements of Operations for the years ended September 30, 2008, and September 30, 2007, and the period from inception to September 30, 2008;
- F-4 Statement of Stockholders' Equity for period from inception to September 30, 2008;
- F-5 Statements of Cash Flows for the years ended September 30, 2008, and September 30, 2007, and the period from inception to September 30, 2008;
- F-6 Notes to Financial Statements

| <u>Exhibit<br/>Number</u> | <u>Description</u>  |
|---------------------------|---|
| 3.1                       | Articles of Incorporation, as amended <sup>(1)</sup>  |
| 3.2                       | Bylaws, as amended <sup>(1)</sup>   |
| 23.1                      | Consent of Maddox Ungar Silberstein, PLLC, Certified Public Accountants   |
| 31.1                      | Certification of Chief Executive Officer pursuant to Securities Exchange Act Rule 13a-14(a)/15d-14(a), as adopted pursuant to Section 302 of the Sarbanes-Oxley Act of 2002   |
| 31.2                      | Certification of Chief Financial Officer pursuant to Securities Exchange Act Rule 13a-14(a)/15d-14(a), as adopted pursuant to Section 302 of the Sarbanes-Oxley Act of 2002   |
| 32.1                      | Certification of Chief Executive Officer and Chief Financial Officer pursuant to 18 U.S.C. Section 1350, as adopted pursuant to Section 906 of the Sarbanes-Oxley Act of 2002 |

<sup>1</sup> Incorporated by reference to the Registration Statement on Form SB-2 filed on October 22, 2007.



## SIGNATURES

In accordance with Section 13 or 15(d) of the Exchange Act, the registrant caused this report to be signed on its behalf by the undersigned, thereunto duly authorized.

Windstar, Inc.

By: /s/ Siew Mee Fam

Siew Mee Fam  
President, Chief Executive Officer, Principal Executive Officer,  
Chief Financial Officer, Principal Financial Officer, Principal Accounting Officer and Director

January 6, 2008

In accordance with Section 13 or 15(d) of the Exchange Act, this report has been signed below by the following persons on behalf of the registrant and in the capacities and on the dates indicated:

By: /s/ Siew Mee Fam

Siew Mee Fam  
President, Chief Executive Officer, Principal Executive Officer,  
Chief Financial Officer, Principal Financial Officer, Principal Accounting Officer and Director

January 6, 2008

By: /s/ Sze Yein Wong

Sze Yein Wong  
Director

January 6, 2008

**REPORT OF INDEPENDENT REGISTERED PUBLIC ACCOUNTING FIRM**

To the Board of Directors of  
Windstar, Inc.  
Reno, Nevada

We have audited the accompanying balance sheet of Windstar, Inc. as of September 30, 2008 and 2007, and the related statements of operations, stockholders' equity, and cash flows for the periods then ended. These financial statements are the responsibility of the Company's management. Our responsibility is to express an opinion on these financial statements based on our audit.

We conducted our audits in accordance with the standards of the Public Company Accounting Oversight Board (United States). Those standards require that we plan and perform the audits to obtain reasonable assurance about whether the financial statements are free of material misstatement. The Company has determined that it is not required to have, nor were we engaged to perform, an audit of its internal control over financial reporting. Our audits included consideration of internal control over financial reporting as a basis for designing audit procedures that are appropriate in the circumstances, but not for the purpose of expressing an opinion on the effectiveness of the Company's internal control over financial reporting. Accordingly, we express no such opinion. An audit includes examining on a test basis, evidence supporting the amounts and disclosures in the financial statements. An audit also includes assessing the accounting principles used and significant estimates made by management, as well as evaluating the overall financial statement presentation. We believe that our audits provide a reasonable basis for our opinion.

In our opinion, the financial statements referred to above present fairly, in all material respects, the financial position of Windstar, Inc. as of September 30, 2008 and 2007, and the results of its operations and cash flows for the periods then ended, in conformity with accounting principles generally accepted in the United States of America.

The accompanying consolidated financial statements have been prepared assuming that the Company will continue as a going concern. As discussed in Note 5 to the financial statements, the Company has negative working capital, has not yet received revenue from sales of products or services, and has incurred losses since inception. These factors raise substantial doubt about the Company's ability to continue as a going concern. Management's plans with regard to these matters are described in Note 5. The accompanying financial statements do not include any adjustments that might result from the outcome of this uncertainty.

/s/ Maddox Ungar Silberstein, PLLC

Maddox Ungar Silberstein, PLLC  
Bingham Farms, Michigan  
December 23, 2008

**WINDSTAR , INC.**  
**(A DEVELOPMENT STAGE COMPANY)**  
**BALANCE SHEETS**  
**As of September 30, 2008 and 2007**

|   | <u>2008</u>     | <u>2007</u>      |
|---|-----------------|------------------|
| <b>ASSETS</b>   |                 |                  |
| <b>Current Assets</b>   |                 |                  |
| Cash and equivalents  | \$ -0-          | \$ 35,000        |
| Prepaid expenses  | <u>-0-</u>      | <u>4,000</u>     |
| <b>TOTAL ASSETS</b>   | <u>\$ -0-</u>   | <u>\$ 39,000</u> |
| <b>LIABILITIES AND STOCKHOLDERS' EQUITY<br/>(DEFICIT)</b>         |                 |                  |
| <b>Current Liabilities</b>  |                 |                  |
| Accrued expenses  | <u>\$ 5,500</u> | <u>\$ 0</u>      |
| <b>Stockholders' Equity (Deficit)</b>                             |                 |                  |
| Common Stock, \$.001 par value, 100,000,000<br>shares authorized, |                 |                  |
| 2,150,000 shares issued and outstanding                           | 2,150           | 2,150            |
| Additional paid-in capital  | 40,850          | 40,850           |
| Deficit accumulated during the development stage                  | <u>(48,500)</u> | <u>(4,000)</u>   |
| Total stockholders' equity (deficit)                              | <u>(5,500)</u>  | <u>39,000</u>    |
| <b>TOTAL LIABILITIES AND STOCKHOLDERS'<br/>EQUITY (DEFICIT)</b>   | <u>\$ -0-</u>   | <u>\$ 39,000</u> |

*See accompanying notes to financial statements.*

**WINDSTAR , INC.**  
**(A DEVELOPMENT STAGE COMPANY)**  
**STATEMENTS OF OPERATIONS**  
**Years Ended September 30, 2008 and 2007**  
**Period from September 6, 2007 (Inception) to September 30, 2008**

|   | Year Ended<br>September 30,<br>2008 | Year Ended<br>September 30,<br>2007 | Period from<br>September 6,<br>2007<br>(Inception) to<br>September 30,<br>2008 |
|---|-------------------------------------|-------------------------------------|--|
| Revenues                                | \$ -0-                              | \$ -0-                              | \$ -0-   |
| Expenses:                               |                                     |                                     |  |
| Professional fees                       | 44,500                              | 4,000                               | 48,500   |
| Net Loss                                | <u>\$ (44,500)</u>                  | <u>\$ (4,000)</u>                   | <u>\$ (48,500)</u>   |
| Net loss per share:                     |                                     |                                     |  |
| Basic and diluted                       | <u>\$ (0.02)</u>                    | <u>\$ (0.00)</u>                    | <u>\$ (0.02)</u>   |
| Weighted average shares<br>outstanding: |                                     |                                     |  |
| Basic and diluted                       | <u>2,150,000</u>                    | <u>2,150,000</u>                    | <u>2,150,000</u>   |

*See accompanying notes to financial statements.*

**WINDSTAR , INC.**  
**(A DEVELOPMENT STAGE COMPANY)**  
**STATEMENT OF STOCKHOLDERS' EQUITY (DEFICIT)**  
**Period from September 6, 2007 (Inception) to September 30, 2008**

|  | <u>Common stock</u> |                 | Additional<br>paid-in<br>capital | Deficit<br>accumulated<br>during the<br>development<br>stage | Total             |
|--|---------------------|-----------------|----------------------------------|--|-------------------|
|  | Shares              | Amount          |                                  |  |                   |
| Issuance of common stock for cash<br>@\$.001             | 2,150,000           | \$ 2,150        | \$ 40,850                        | \$ -   | \$ 43,000         |
| Net loss for the period ended<br>September 30, 2007      | -                   | -               | -                                | (4,000)  | (4,000)           |
| Balance, September 30, 2007                              | 2,150,000           | 2,150           | 40,850                           | (4,000)  | 39,000            |
| Net loss for the nine months ended<br>September 30, 2008 | -                   | -               | -                                | (44,500)   | (44,500)          |
| Balance, September 30, 2008                              | <u>2,150,000</u>    | <u>\$ 2,150</u> | <u>\$ 40,850</u>                 | <u>\$ (48,500)</u>   | <u>\$ (5,500)</u> |

*See accompanying notes to financial statements.*

**WINDSTAR , INC.**  
**(A DEVELOPMENT STAGE COMPANY)**  
**STATEMENTS OF CASH FLOWS**  
**Years Ended September 30, 2008 and 2007**  
**Period from September 6, 2007 (Inception) to September 30, 2008**

|  | <b>Year Ended<br/>September 30,<br/>2008</b> | <b>Year Ended<br/>September 30,<br/>2007</b> | <b>Period From<br/>September 6,<br/>2007<br/>(Inception) to<br/>September 30,<br/>2008</b> |
|--|--|--|--|
| <b>CASH FLOWS FROM OPERATING<br/>ACTIVITIES</b>    |  |  |  |
| Net loss   | \$ (44,500)                                  | \$ (4,000)                                   | \$ (48,500)  |
| Change in non-cash working capital items           |  |  |  |
| Prepaid expenses                                   | 4,000  | (4,000)                                      | -0-  |
| Accrued expenses                                   | 5,500  | -0-  | 5,500  |
| <b>CASH FLOWS USED BY OPERATING<br/>ACTIVITIES</b> | <b>(35,000)</b>                              | <b>(8,000)</b>                               | <b>(43,000)</b>  |
| <b>CASH FLOWS FROM FINANCING<br/>ACTIVITIES</b>    |  |  |  |
| Proceeds from sales of common stock                | -0-  | 43,000                                       | 43,000   |
| <b>NET INCREASE (DECREASE) IN CASH</b>             | <b>(35,000)</b>                              | <b>35,000</b>                                | <b>-0-</b>   |
| Cash, beginning of period                          | 35,000                                       | -0-  | -0-  |
| Cash, end of period                                | \$ -0-                                       | \$ 35,000                                    | \$ -0-   |
| <b>SUPPLEMENTAL CASH FLOW<br/>INFORMATION</b>      |  |  |  |
| Interest paid                                      | \$ -0-                                       | \$ -0-                                       | \$ -0-   |
| Income taxes paid                                  | \$ -0-                                       | \$ -0-                                       | \$ -0-   |

*See accompanying notes to financial statements.*

**WINDSTAR , INC.**  
**(A DEVELOPMENT STAGE COMPANY)**  
**NOTES TO THE FINANCIAL STATEMENTS**  
**September 30, 2008**

NOTE 1 – SUMMARY OF ACCOUNTING POLICIES

Nature of Business

Windstar, Inc. (“Windstar”) is a development stage company and was incorporated in Nevada on September 6, 2007. The Company is developing a cooking smoke purifier. Windstar operates out of office space owned by a director and stockholder of the Company. The facilities are provided at no charge. There can be no assurances that the facilities will continue to be provided at no charge in the future.

Development Stage Company

The accompanying financial statements have been prepared in accordance with the Statement of Financial Accounting Standards No. 7 “Accounting and Reporting by Development-Stage Enterprises”. A development-stage enterprise is one in which planned principal operations have not commenced or if its operations have commenced, there has been no significant revenues there from.

Cash and Cash Equivalents

Windstar considers all highly liquid investments with maturities of three months or less to be cash equivalents. At September 30, 2008 the Company had \$0 of cash.

Fair Value of Financial Instruments

Windstar’s financial instruments consist of cash and cash equivalents. The carrying amount of these financial instruments approximates fair value due either to length of maturity or interest rates that approximate prevailing market rates unless otherwise disclosed in these financial statements.

Income Taxes

Income taxes are computed using the asset and liability method. Under the asset and liability method, deferred income tax assets and liabilities are determined based on the differences between the financial reporting and tax bases of assets and liabilities and are measured using the currently enacted tax rates and laws. A valuation allowance is provided for the amount of deferred tax assets that, based on available evidence, are not expected to be realized.

**WINDSTAR, INC.**  
**(A DEVELOPMENT STAGE COMPANY)**  
**NOTES TO THE FINANCIAL STATEMENTS**  
**September 30, 2008**

NOTE 1 – SUMMARY OF ACCOUNTING POLICIES (continued)

Use of Estimates

The preparation of financial statements in conformity with generally accepted accounting principles requires management to make estimates and assumptions that affect the reported amounts of assets and liabilities and disclosure of contingent assets and liabilities at the date the financial statements and the reported amount of revenues and expenses during the reporting period. Actual results could differ from those estimates.

Basic loss per share

Basic loss per share has been calculated based on the weighted average number of shares of common stock outstanding during the period.

Recent Accounting Pronouncements

Windstar does not expect the adoption of recently issued accounting pronouncements to have a significant impact on the Company's results of operations, financial position or cash flow.

NOTE 2 – PREPAID EXPENSES

Prepaid expenses at September 30, 2007 consisted of an advance retainer paid to the firms outside independent auditors for services to be rendered for periods after September 30, 2007.

NOTE 3 – ACCRUED EXPENSES

Accrued expenses at September 30, 2008 consisted of amounts owed to the firms outside independent auditors for services rendered for periods reported on in these financial statements and legal fees owed to the Company's securities law firm for services performed prior to year-end.

NOTE 4 – INCOME TAXES

For the period ended September 30, 2008, Windstar has incurred net losses and, therefore, has no tax liability. The net deferred tax asset generated by the loss carry-forward has been fully reserved. The cumulative net operating loss carry-forward is approximately \$48,500 at September 30, 2008, and will expire beginning in the year 2027.



**WINDSTAR, INC.**  
**(A DEVELOPMENT STAGE COMPANY)**  
**NOTES TO THE FINANCIAL STATEMENTS**  
**September 30, 2008**

## NOTE 4 – INCOME TAXES (continued)

The cumulative tax effect at the expected rate of 34% of significant items comprising our net deferred tax amount is as follows:

|                                     | <u>2008</u> |
|-------------------------------------|-------------|
| Deferred tax asset attributable to: |             |
| Net operating loss carryover        | \$ 16,500   |
| Valuation allowance                 | (16,500)    |
| Net deferred tax asset              | <u>\$ -</u> |

## NOTE 5 – LIQUIDITY AND GOING CONCERN

Windstar has negative working capital, has not yet received revenues from sales of products or services, and has incurred losses since inception. These factors create substantial doubt about the Company's ability to continue as a going concern. The financial statements do not include any adjustment that might be necessary if the Company is unable to continue as a going concern.

The ability of Windstar to continue as a going concern is dependent on the Company generating cash from the sale of its common stock and/or obtaining debt financing and attaining future profitable operations. Management's plans include selling its equity securities and obtaining debt financing to fund its capital requirement and ongoing operations; however, there can be no assurance the Company will be successful in these efforts.



## CERTIFICATIONS

I, Siew Mee Fam, certify that;

- (1) I have reviewed this annual report on Form 10-K of Windstar, Inc.;
- (2) Based on my knowledge, this report does not contain any untrue statement of a material fact or omit to state a material fact necessary to make the statements made, in light of the circumstances under which such statements were made, not misleading with respect to the period covered by this report;
- (3) Based on my knowledge, the financial statements, and other financial information included in this report, fairly present in all material respects the financial condition, results of operations and cash flows of the small business issuer as of, and for, the periods presented in this report;
- (4) The small business issuer's other certifying officer(s) and I are responsible for establishing and maintaining disclosure controls and procedures (as defined in Exchange Act Rules 13a-15(e) and 15d-15(e)) for the small business issuer and have:
  - a) Designed such disclosure controls and procedures, or caused such disclosure controls and procedures to be designed under our supervision, to ensure that material information relating to the small business issuer, including its consolidated subsidiaries, is made known to us by others within those entities, particularly during the period in which this report is being prepared;
  - b) Evaluated the effectiveness of the small business issuer's disclosure controls and procedures and presented in this report our conclusions about the effectiveness of the disclosure controls and procedures, as of the end of the period covered by this report based on such evaluation; and
  - c) Disclosed in this report any change in the small business issuer's internal control over financial reporting that occurred during the small business issuer's most recent fiscal quarter (the small business issuer's fourth quarter in the case of an annual report) that has materially affected, or is reasonably likely to materially affect, the small business issuer's internal control over financial reporting; and
- (5) The small business issuer's other certifying officer(s) and I have disclosed, based on our most recent evaluation of the internal control over financial reporting, to the small business issuer's auditors and the audit committee of small business issuer's board of directors (or persons performing the equivalent functions):
  - a) All significant deficiencies and material weaknesses in the design or operation of internal control over financial reporting which are reasonably likely to adversely affect the small business issuer's ability to record, process, summarize and report financial information; and
  - b) Any fraud, whether or not material, that involves management or other employees who have a significant role in the small business issuer's internal control over financial reporting.

Date: January 6, 2008

/s/ Siew Mee Fam

By: Siew Mee Fam

Title: Chief Executive Officer

## CERTIFICATIONS

I, Siew Mee Fam, certify that;

- (1) I have reviewed this annual report on Form 10-K of Windstar, Inc.;
- (2) Based on my knowledge, this report does not contain any untrue statement of a material fact or omit to state a material fact necessary to make the statements made, in light of the circumstances under which such statements were made, not misleading with respect to the period covered by this report;
- (3) Based on my knowledge, the financial statements, and other financial information included in this report, fairly present in all material respects the financial condition, results of operations and cash flows of the small business issuer as of, and for, the periods presented in this report;
- (4) The small business issuer's other certifying officer(s) and I are responsible for establishing and maintaining disclosure controls and procedures (as defined in Exchange Act Rules 13a-15(e) and 15d-15(e)) for the small business issuer and have:
  - a) Designed such disclosure controls and procedures, or caused such disclosure controls and procedures to be designed under our supervision, to ensure that material information relating to the small business issuer, including its consolidated subsidiaries, is made known to us by others within those entities, particularly during the period in which this report is being prepared;
  - b) Evaluated the effectiveness of the small business issuer's disclosure controls and procedures and presented in this report our conclusions about the effectiveness of the disclosure controls and procedures, as of the end of the period covered by this report based on such evaluation; and
  - c) Disclosed in this report any change in the small business issuer's internal control over financial reporting that occurred during the small business issuer's most recent fiscal quarter (the small business issuer's fourth quarter in the case of an annual report) that has materially affected, or is reasonably likely to materially affect, the small business issuer's internal control over financial reporting; and
- (5) The small business issuer's other certifying officer(s) and I have disclosed, based on our most recent evaluation of the internal control over financial reporting, to the small business issuer's auditors and the audit committee of small business issuer's board of directors (or persons performing the equivalent functions):
  - a) All significant deficiencies and material weaknesses in the design or operation of internal control over financial reporting which are reasonably likely to adversely affect the small business issuer's ability to record, process, summarize and report financial information; and
  - b) Any fraud, whether or not material, that involves management or other employees who have a significant role in the small business issuer's internal control over financial reporting.

Date: January 6, 2008

/s/ Siew Mee Fam

By: Siew Mee Fam

Title: Chief Financial Officer

CERTIFICATION OF CHIEF EXECUTIVE OFFICER AND  
CHIEF FINANCIAL OFFICER  
PURSUANT TO  
18 U.S.C. SECTION 1350,  
AS ADOPTED PURSUANT TO  
SECTION 906 OF THE SARBANES-OXLEY ACT OF 2002

In connection with the accompanying annual Report on Form 10-K of Windstar, Inc. for the year ended September 30, 2008, I certify, pursuant to 18 U.S.C. Section 1350, as adopted pursuant to Section 906 of the Sarbanes-Oxley Act of 2002, to my knowledge, that:

- (1) the annual Report on Form 10-K of Windstar, Inc. for the year ended September 30, 2008 fully complies with the requirements of Section 13(a) or 15(d) of the Securities Exchange Act of 1934; and
- (2) the information contained in the annual Report on Form 10-K for the year ended September 30, 2008, fairly presents in all material respects, the financial condition and results of operations of Windstar, Inc.

By: /s/ Siew Mee Fam  
Name: Siew Mee Fam  
Title: Principal Executive Officer, Principal Financial Officer and  
Director  
Date: January 6, 2008